

Examples: Version 9.5

This is a collection of diagrams the author has had occasion to produce using m4 circuit macros and others, and gpic or dpic. In some cases there are other or better m4 or pic constructs for producing the same drawings, but the source-file names are shown for reference. Most of the examples can be processed using either dpic -p, dpic -g, or gpic -t, but the possibility of other postprocessing has meant that sometimes the source is slightly more complicated than it would be if only one workflow had been assumed. Some of the examples require dpic. The most simplicity and elegance is achieved by sticking to one pic interpreter and one postprocessor.

This document duplicates a few diagrams from the manual Circuit_macros.pdf. There are also a few files in the examples directory that are not included in this document. To process *file.m4*, for example, type "make *file.pdf*."

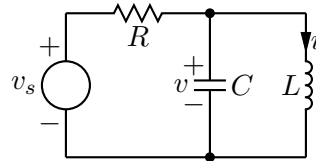

Figure 1: The quick-start example from the manual [quick.m4].

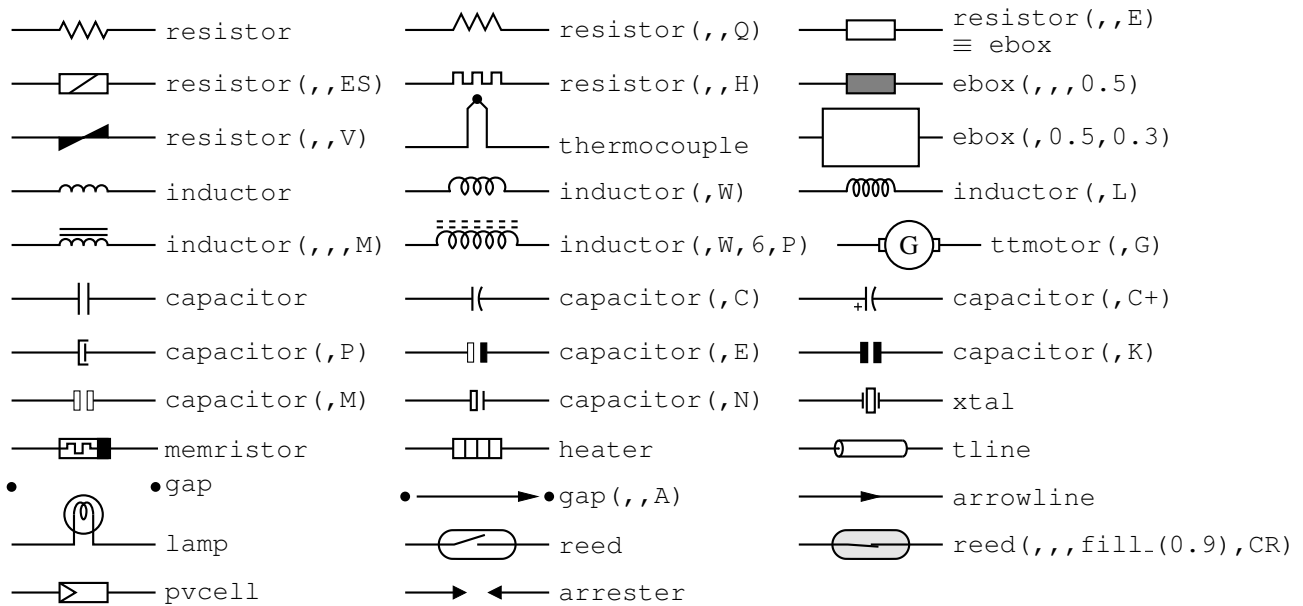

Figure 2: Two-terminal elements, showing some variations [CctTable.m4].

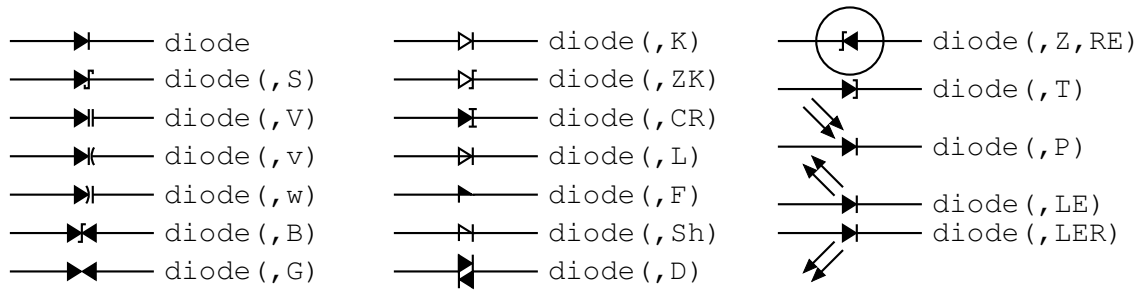

Figure 3: Diodes: a K in the second argument draws an open arrowhead [Diodes.m4].

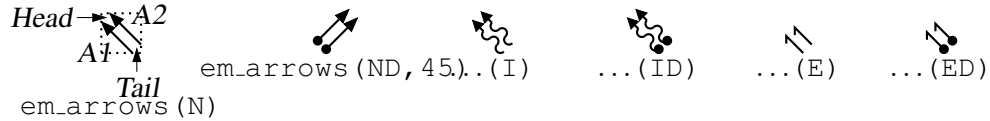

Figure 4: Radiation arrows [Emarrows.m4].

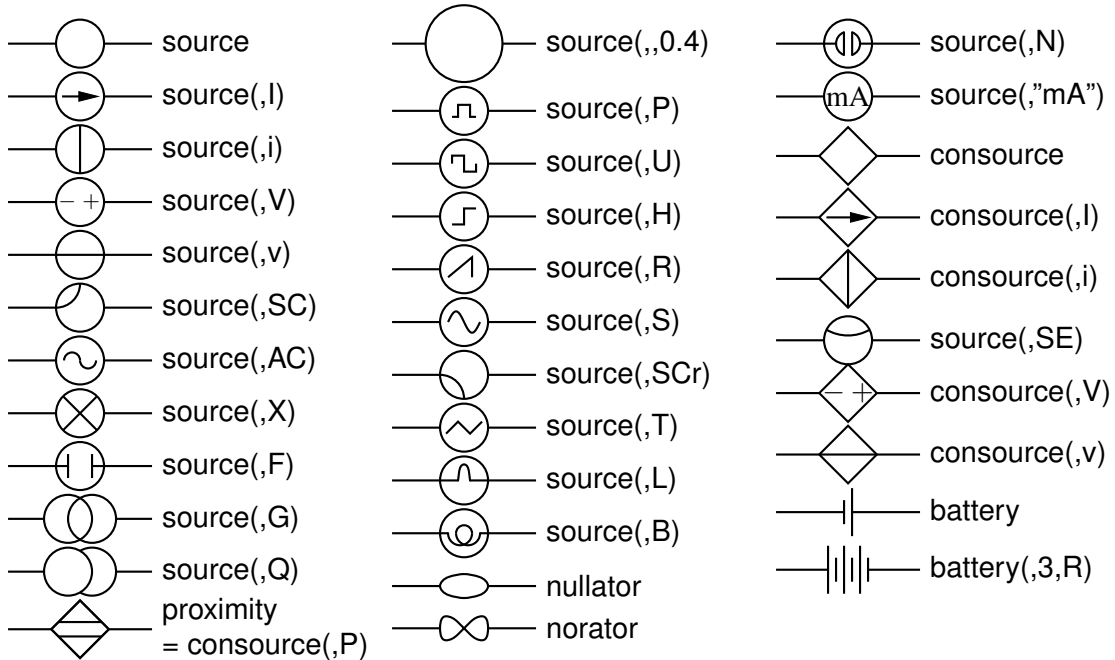

Figure 5: Sources and source-like elements [Sources.m4].

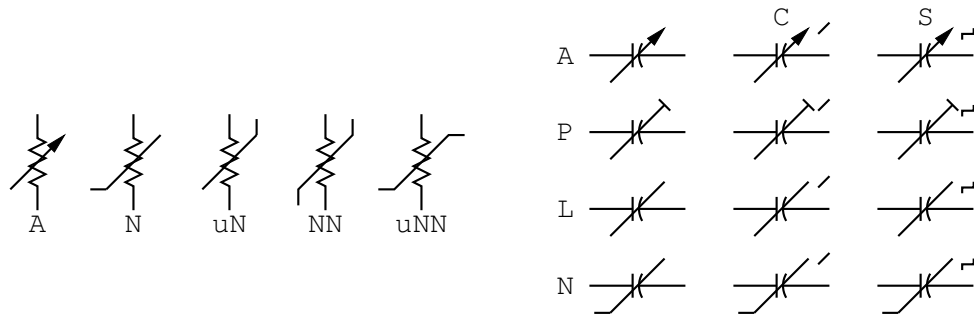

Figure 6: Arrows and marks indicating variability [Variable.m4].

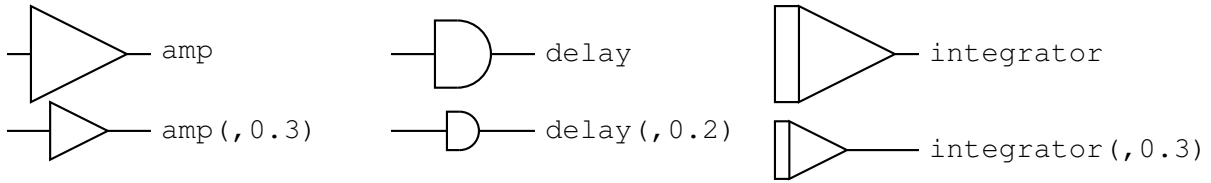

Figure 7: Macros amp, delay, and integrator [AmpTable.m4].

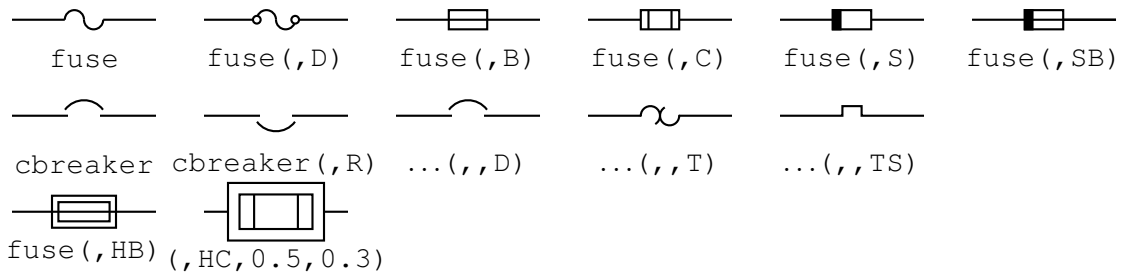

Figure 8: Macros fuse and cbreaker [Fuses.m4].

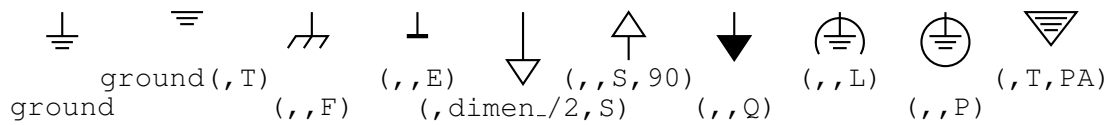

Figure 9: Ground symbols [Grounds.m4].

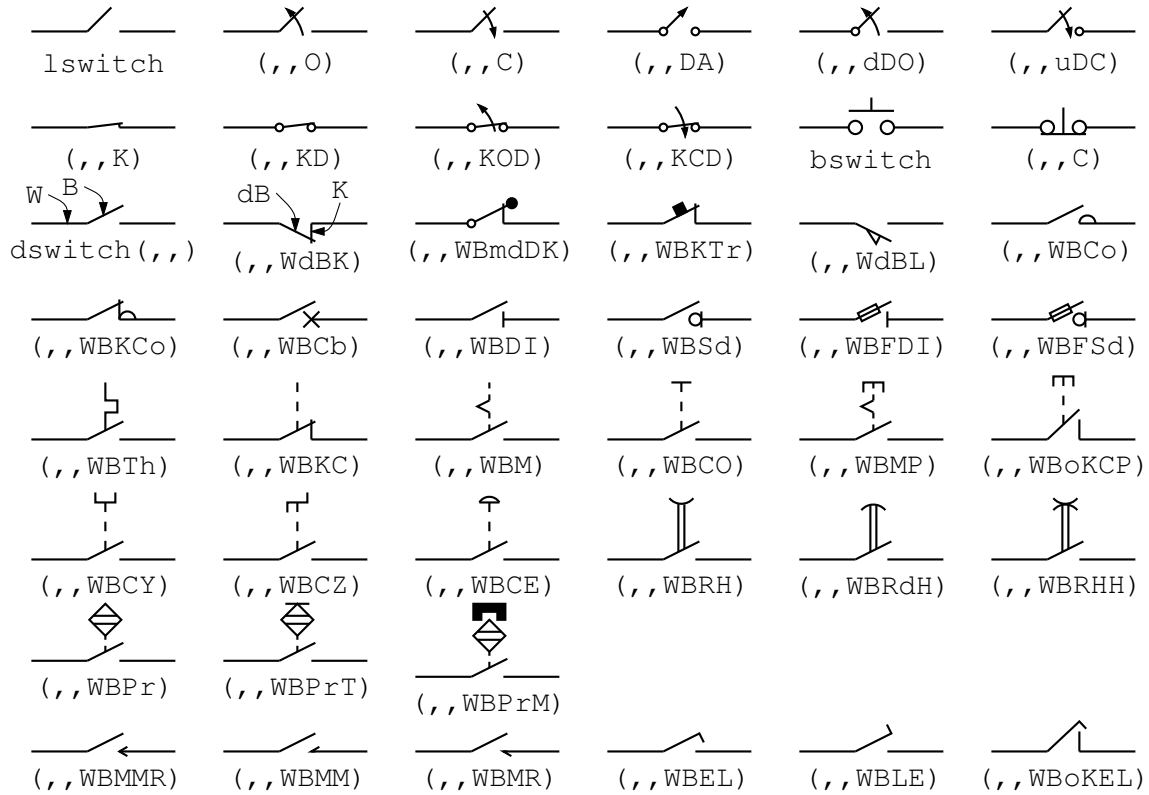

Figure 10: The switch macros; `switch(,,L|B|D)` is a wrapper for `lswitch`, `bswitch`, and `dswitch` [Switches.m4].

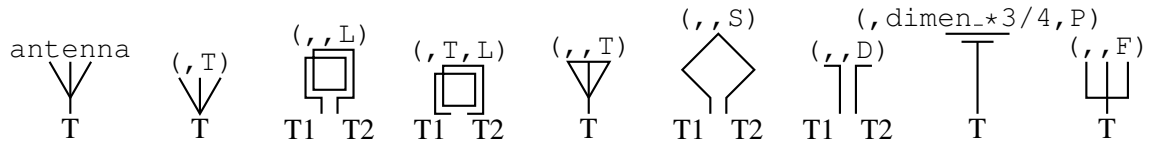

Figure 11: Antenna symbols [Antennas.m4].

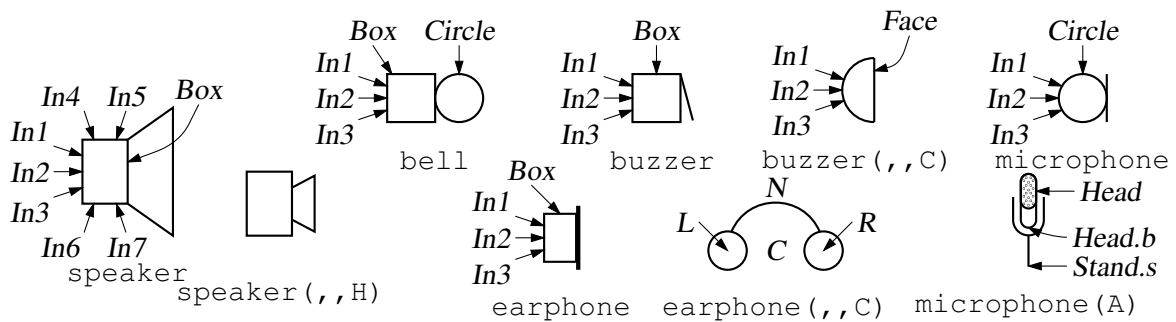

Figure 12: Audio elements [Audio.m4].

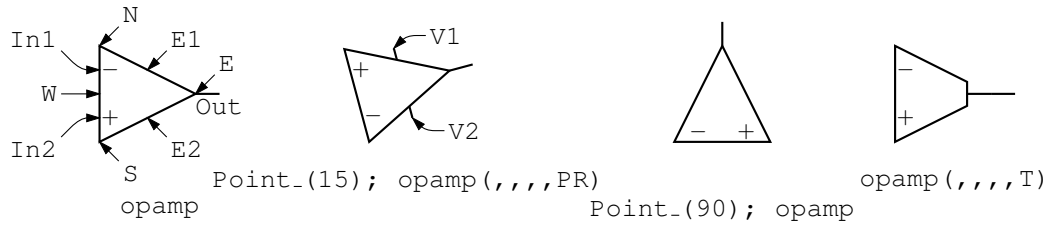

Figure 13: The opamp [Opamp.m4].

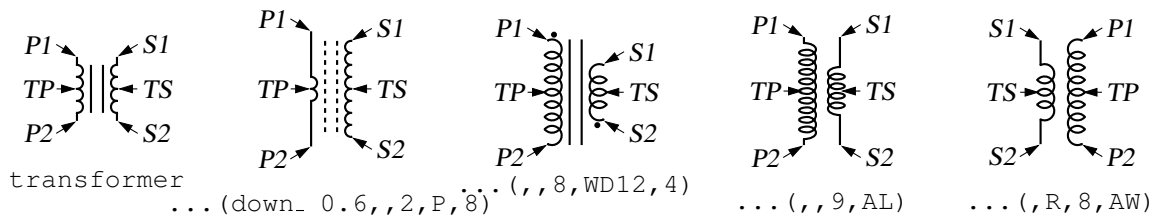

Figure 14: The transformer element, drawing direction down [Xform.m4].

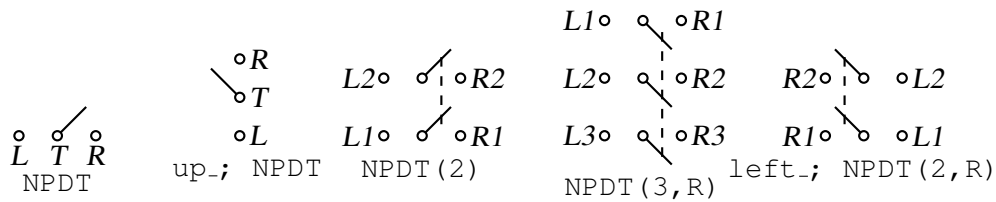

Figure 15: Double throw with the NPDT macro [NPDT.m4].

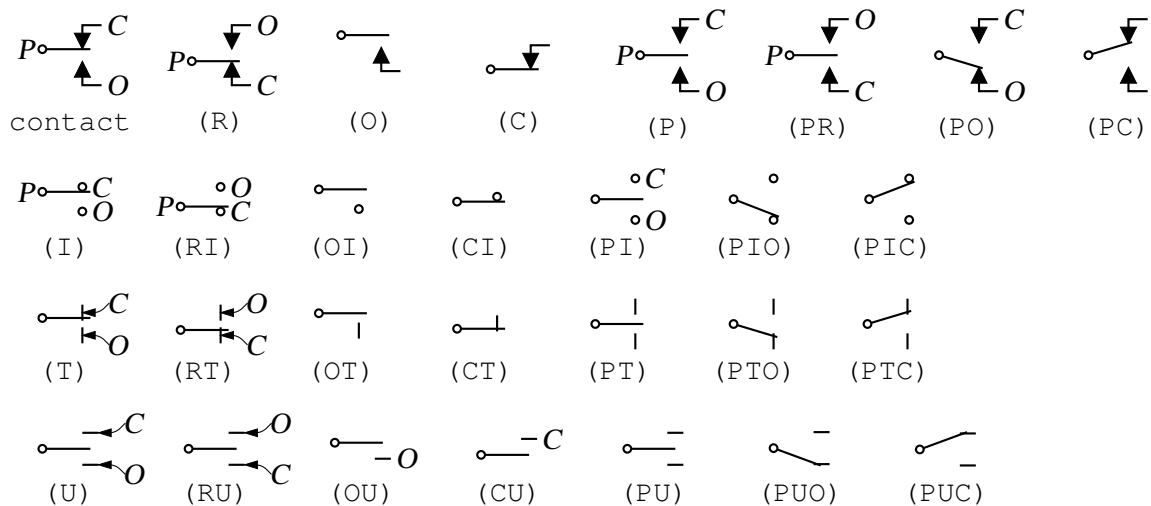

Figure 16: A non-exhaustive sampling of contact macro variations [Contact.m4].

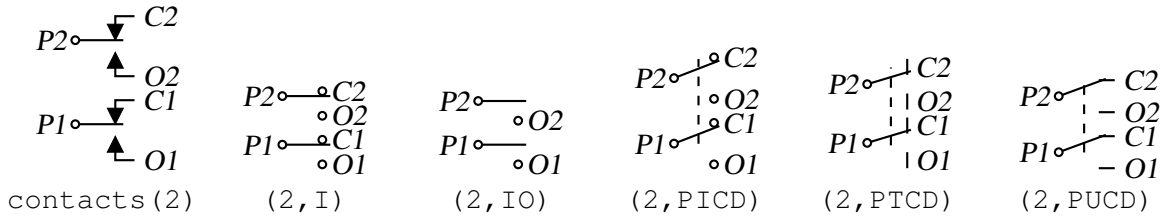

Figure 17: The contacts macro [Contacts.m4].

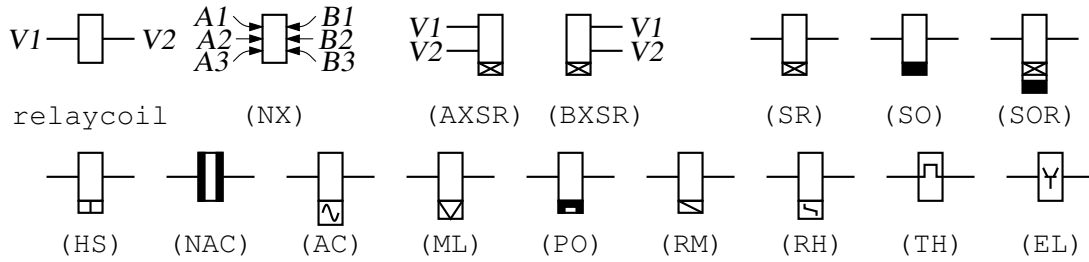

Figure 18: The relaycoil macro [relaycoil.m4].

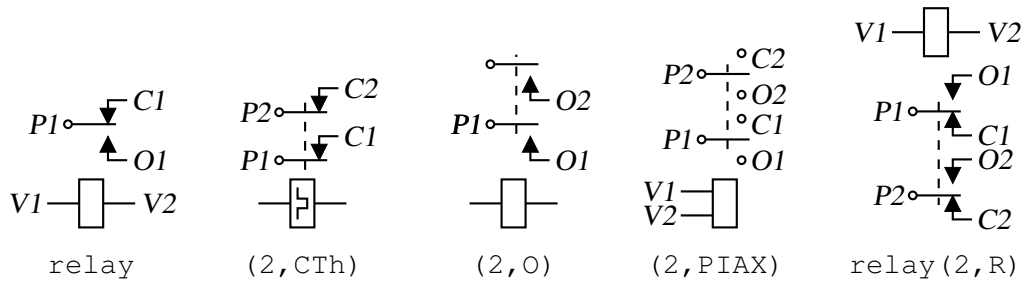

Figure 19: Some variants of the relay macro [Relay.m4].

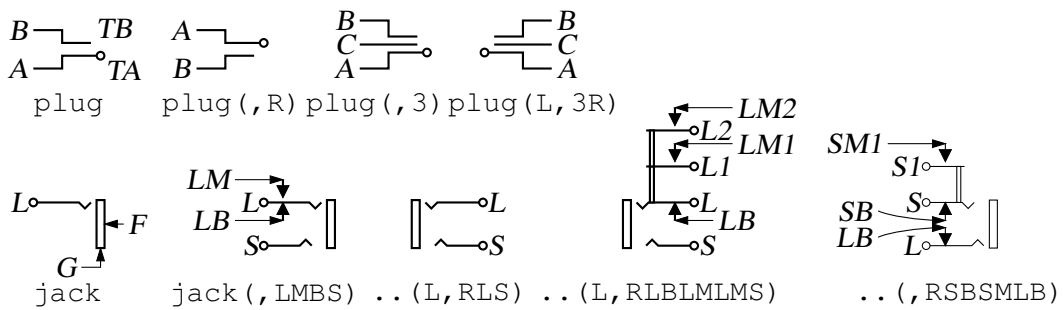

Figure 20: The jack and plug macros [Jack.m4].

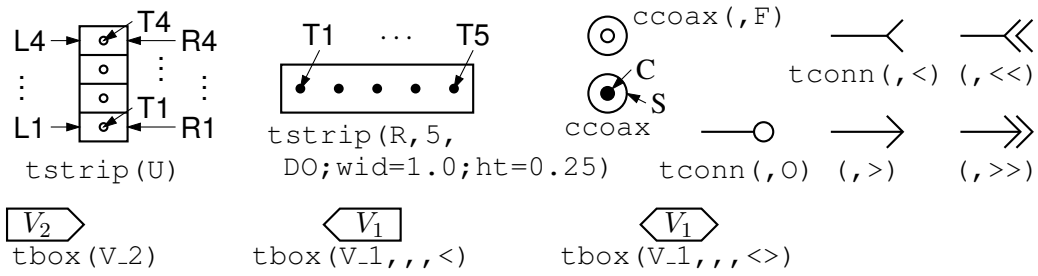

Figure 21: The tstrip, ccoax, tconn, and tbox macros [Conn.m4].

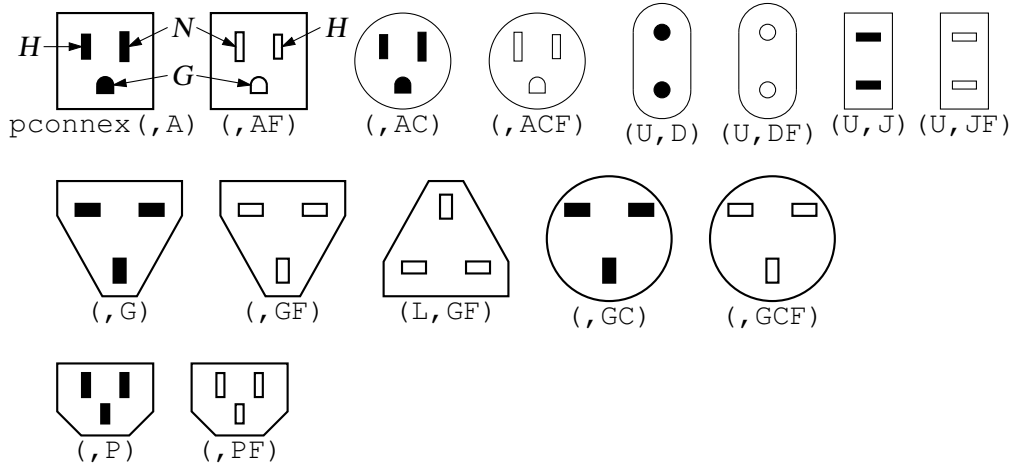

Figure 22: The pconnex macro [Pconn.m4].

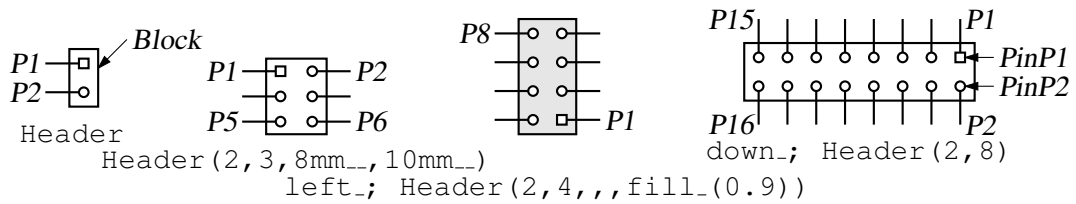

Figure 23: The Header macro [Headers.m4].

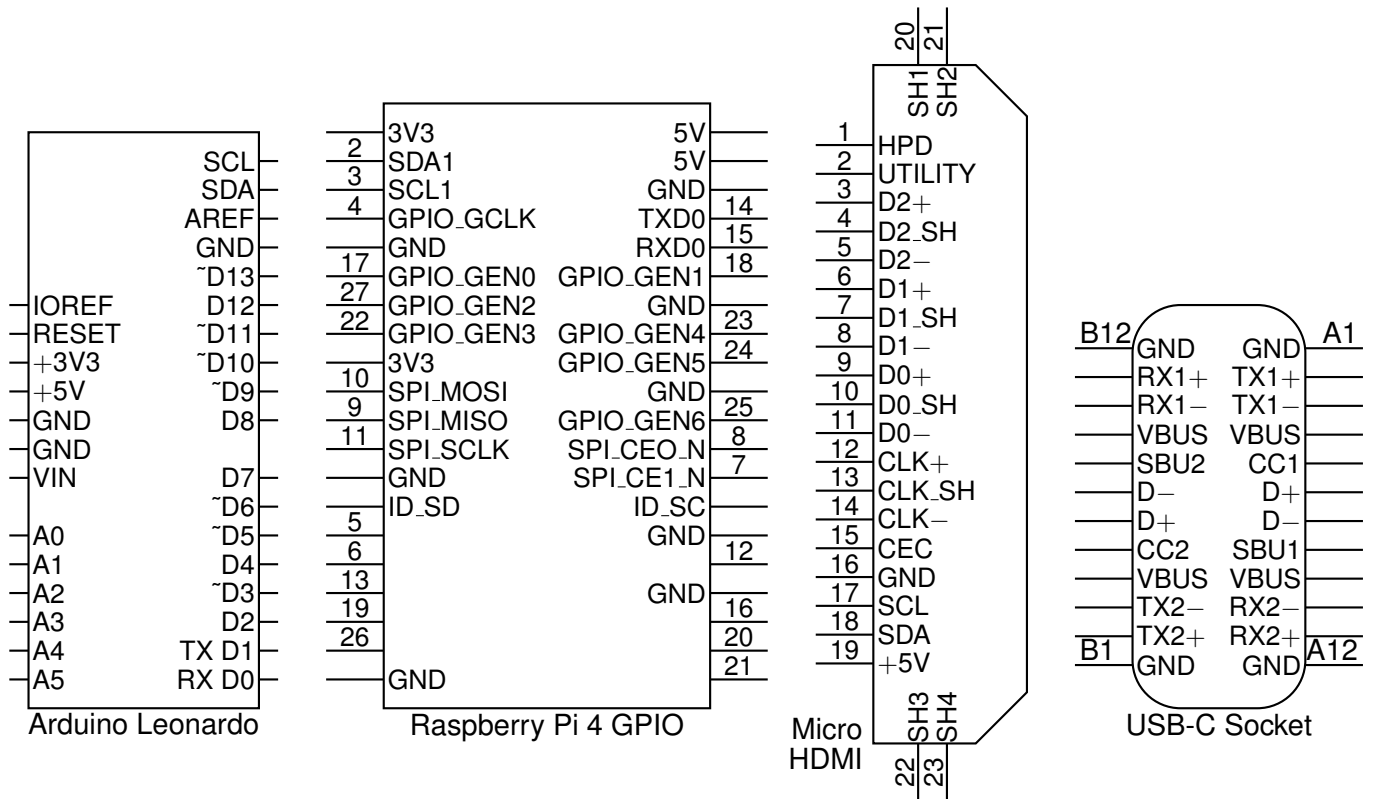

Figure 24: Some connectors with simple geometry and lists of labels [Connectors.m4].

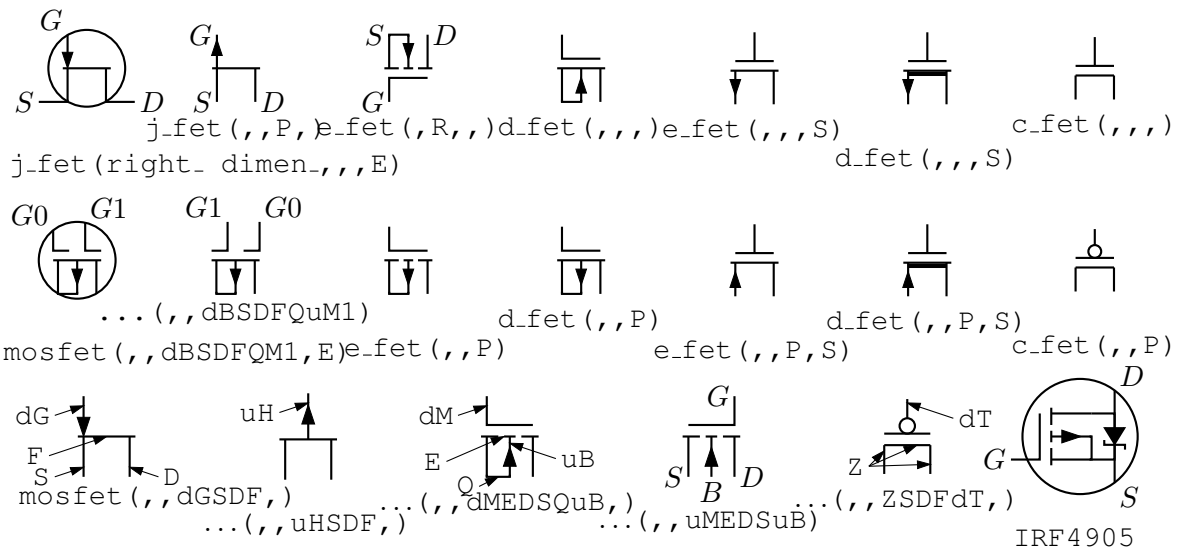

Figure 25: FETs, showing programmable components and example customizations [fet.m4].

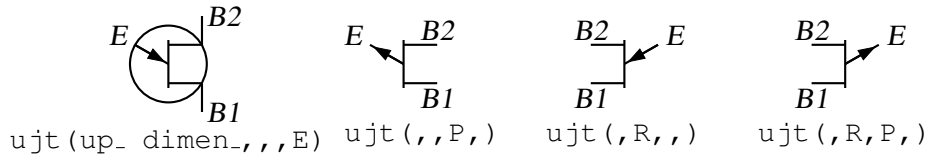

Figure 26: UJT examples [ujt.m4].

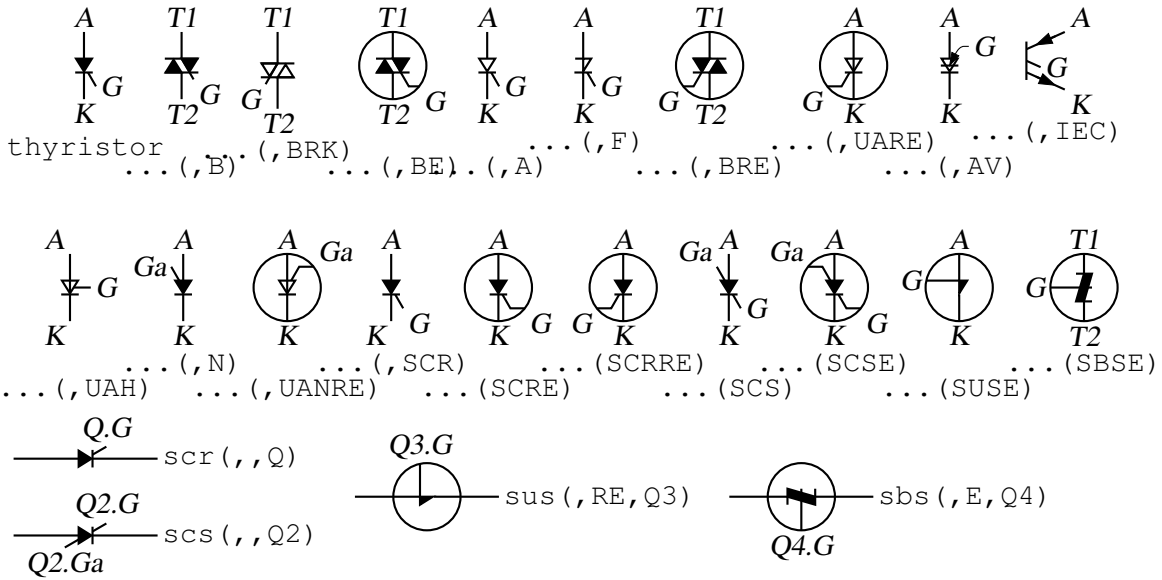

Figure 27: Thyristor examples [thyristor.m4].

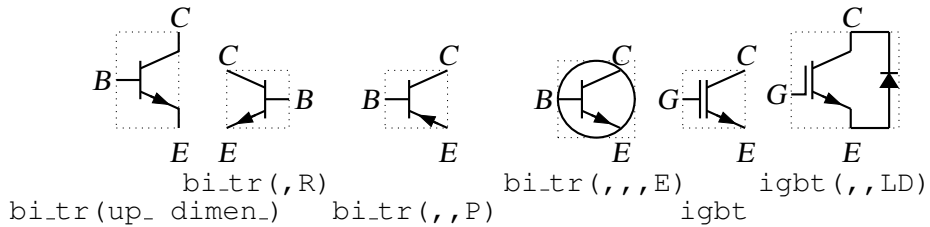

Figure 28: Bipolar transistors (drawing direction: up) [Bip.m4].

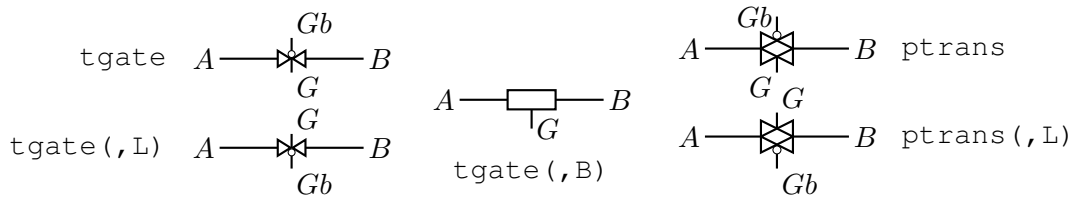

Figure 29: The tgate and ptrans elements [Tgate.m4].

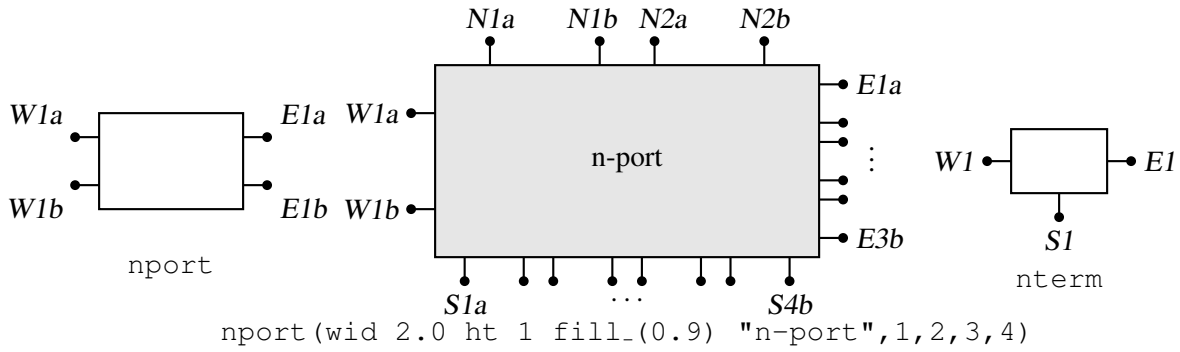

Figure 30: The nport and nterm macros [Nport.m4].

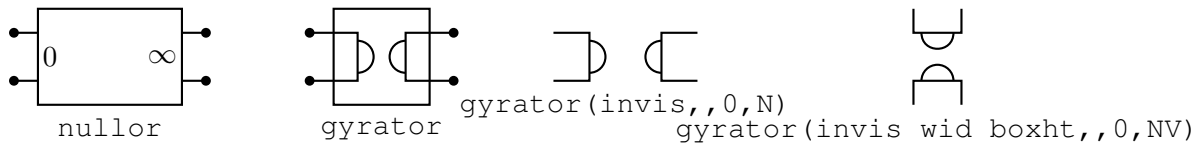

Figure 31: Some customizations of nport [NLG.m4].

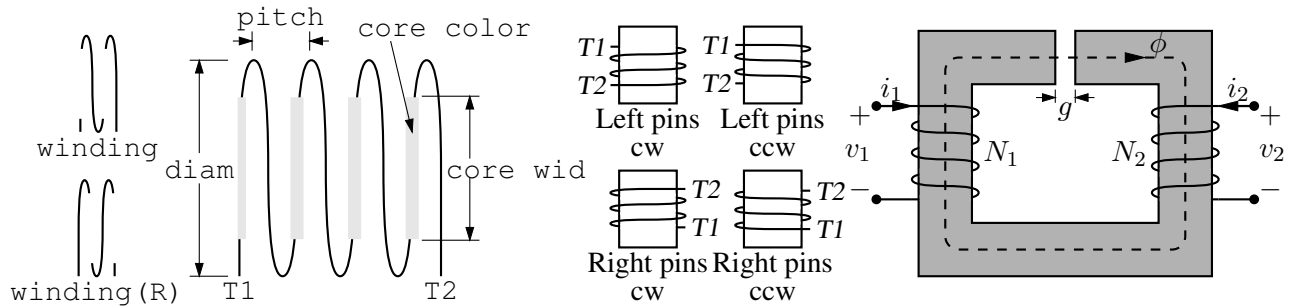

Figure 32: The macro winding(L|R, diam, pitch, turns, core wid, core color) [Windings.m4].

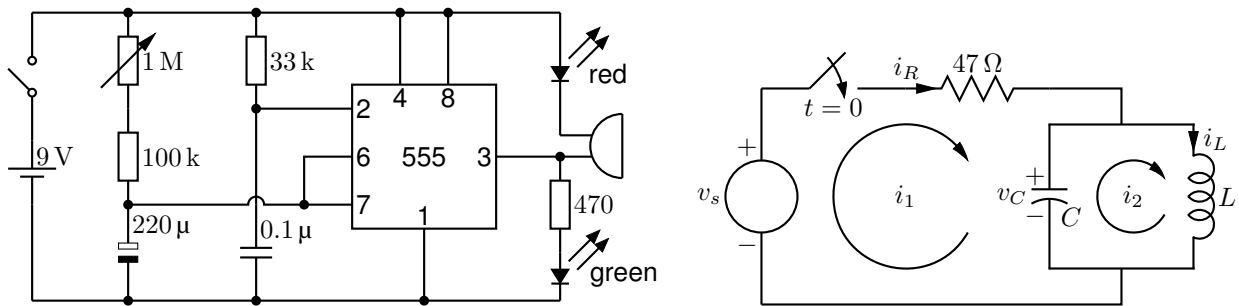

Figure 33: Two simple labeled circuits [ex01.m4].

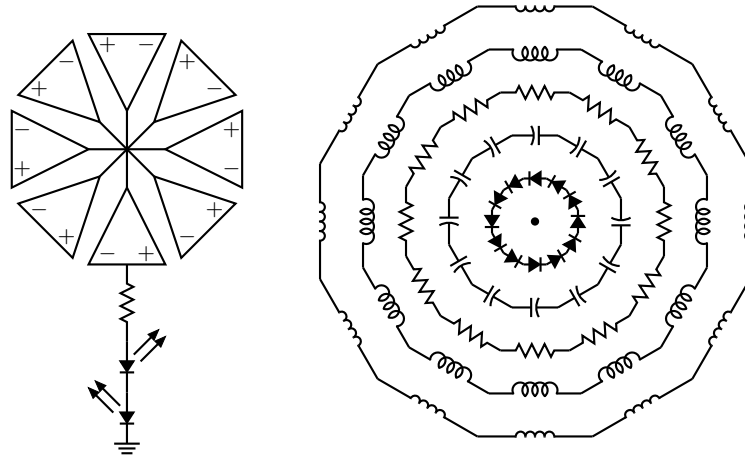

Figure 34: Elements at obtuse angles [ex02.m4].

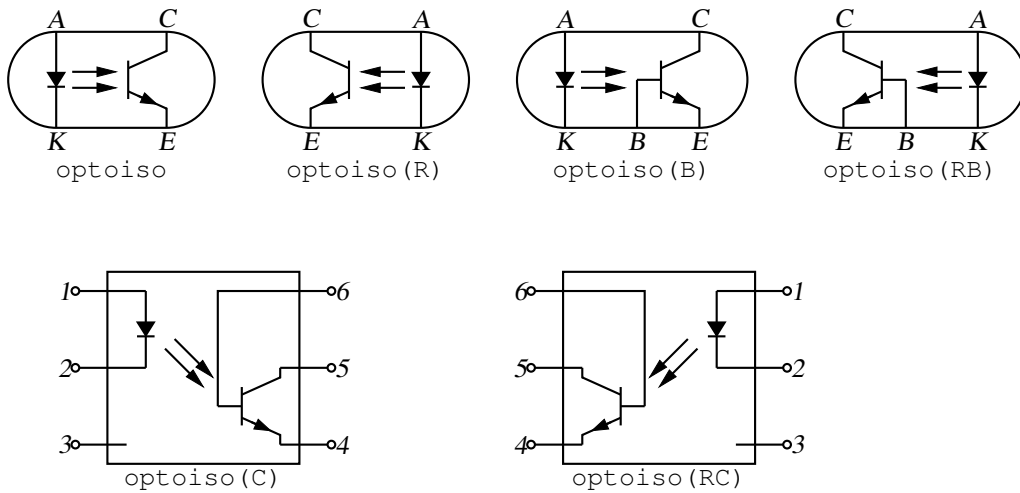

Figure 35: Optical isolator: a circuit with right or left orientation [Optoiso.m4].

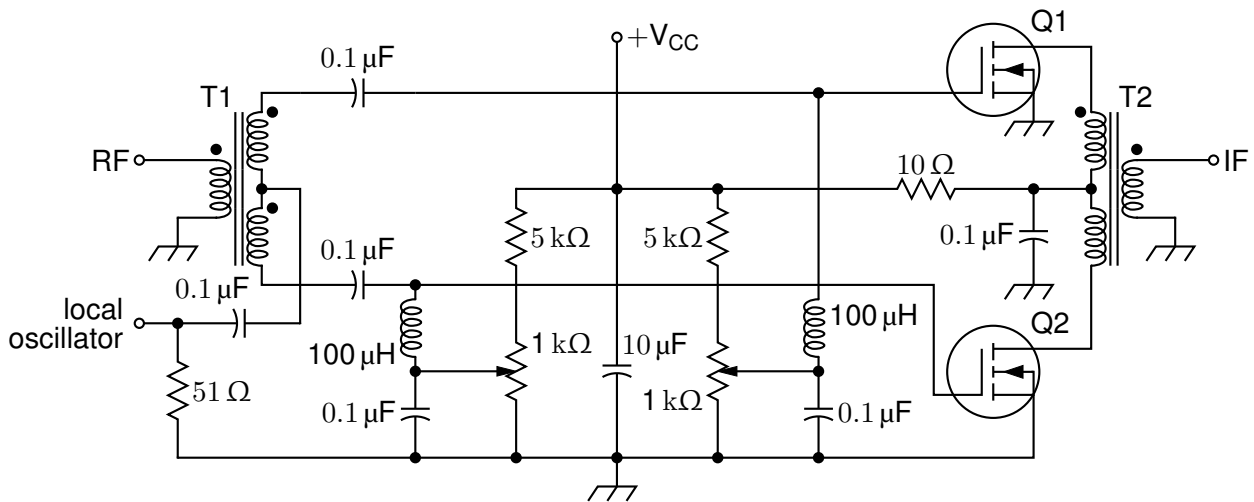

Figure 36: A balanced mixer, using mosfet and a custom transformer [Mixer.m4].

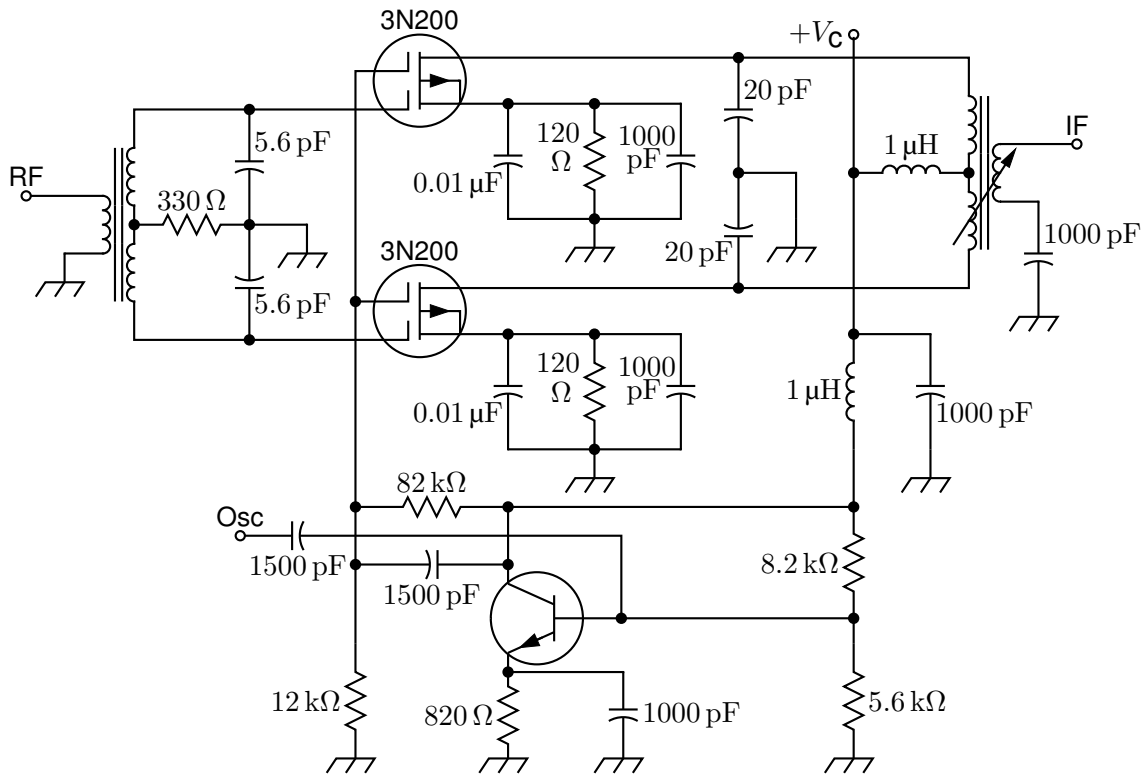

Figure 37: A push-pull mixer, showing FETs with multiple gates [PushPull.m4].

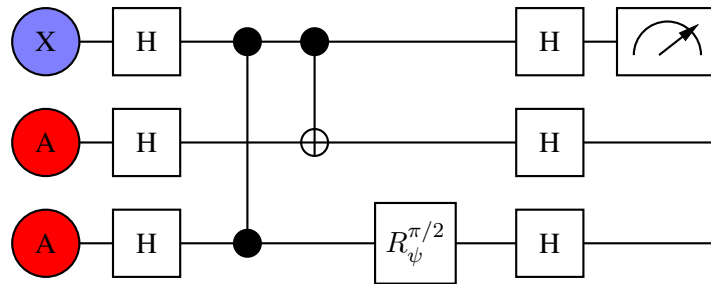

Figure 38: A quantum circuit [Quantum.m4].

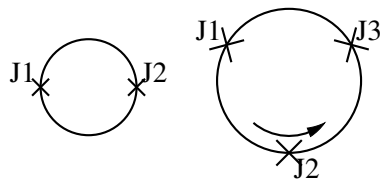

Figure 39: Superconducting quantum interface device (drawing direction down) [SQUID.m4].

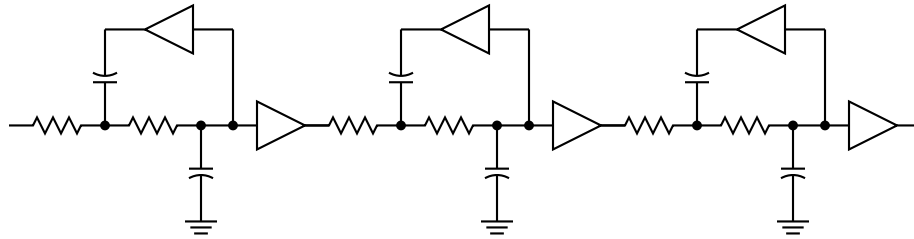

Figure 40: A six-pole filter [Sixpole.m4].

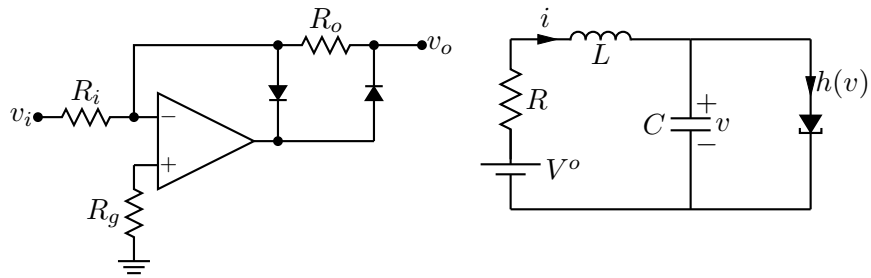

Figure 41: Precision half-wave rectifier and a tunnel diode circuit (illustrating opamp, diode, resistor, ground, and labels) [ex18.m4].

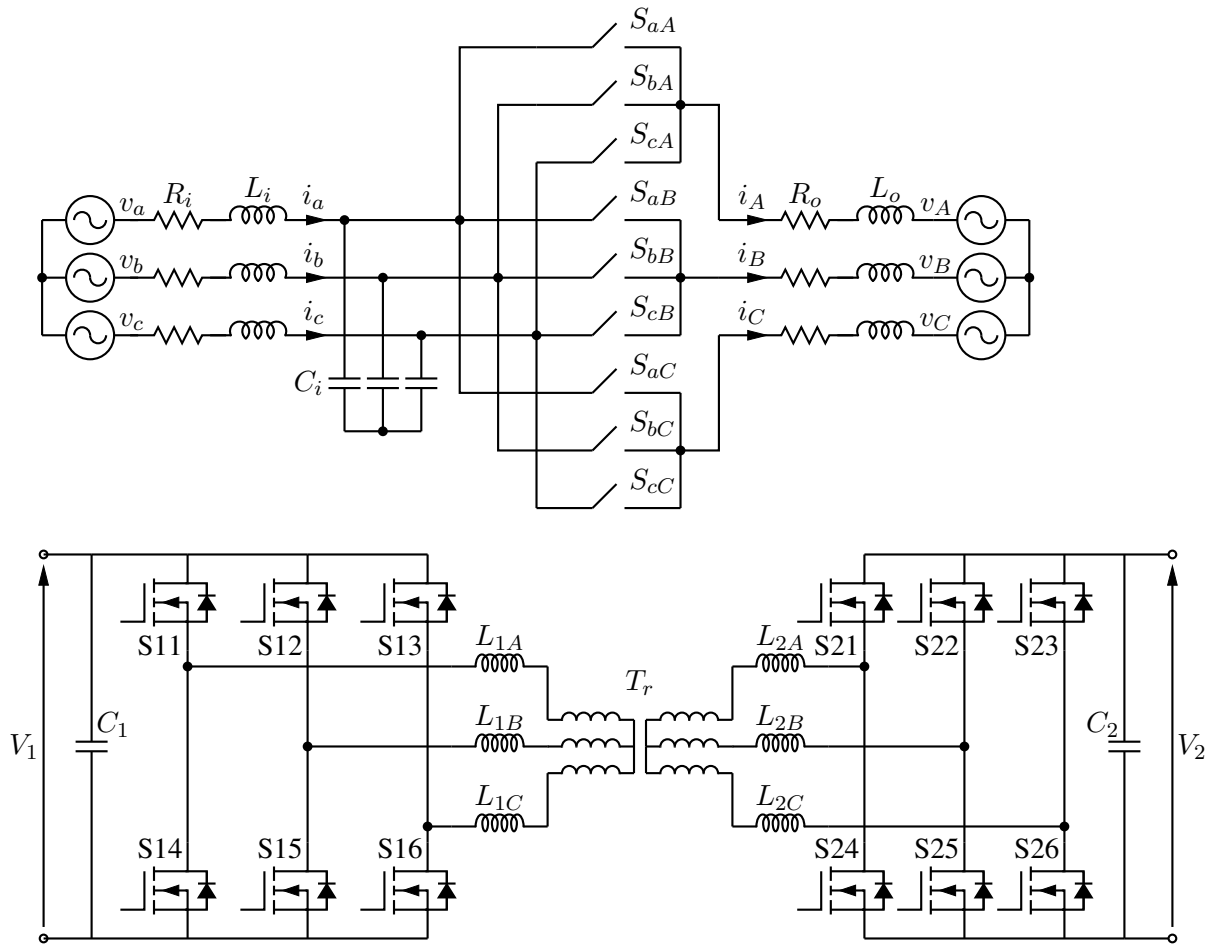

Figure 42: A three-phase switched AC-AC converter and a DC-DC converter [MC.m4].

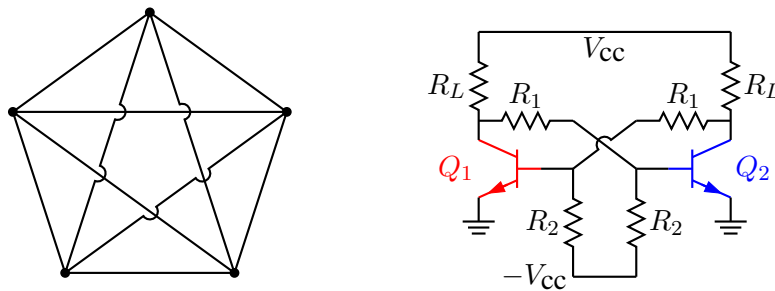

Figure 43: Non-planar graph and bistable circuit (illustrating the crossover macro and colored elements) [ex10.m4].

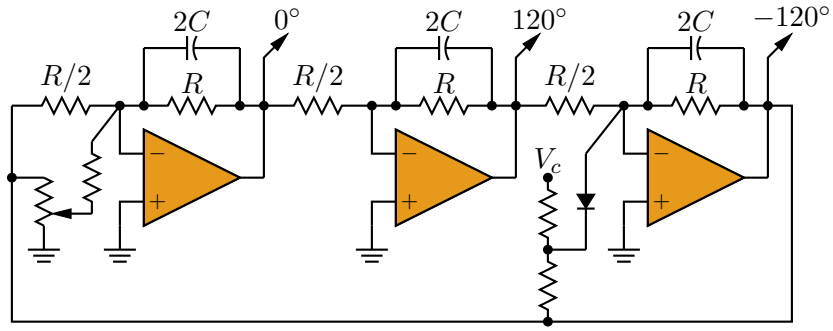

Figure 44: Three-phase oscillator [Three.m4].

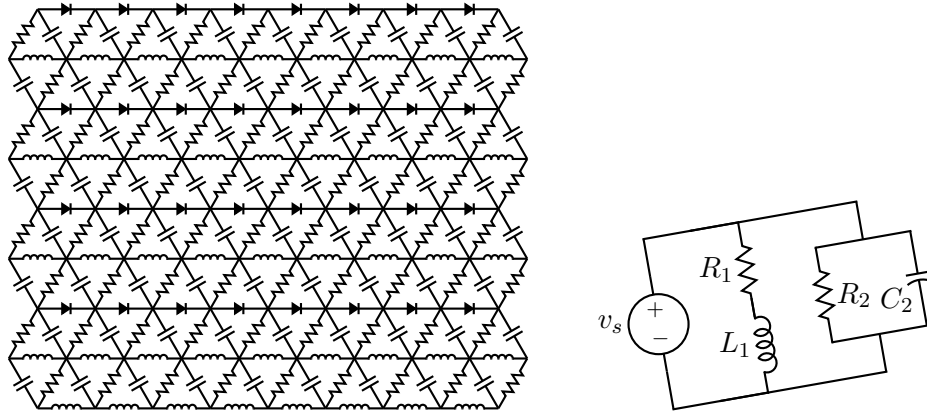

Figure 45: A repetitive network created by Pic looping and a skewed circuit used to test the macro parallel. [ex17.m4].

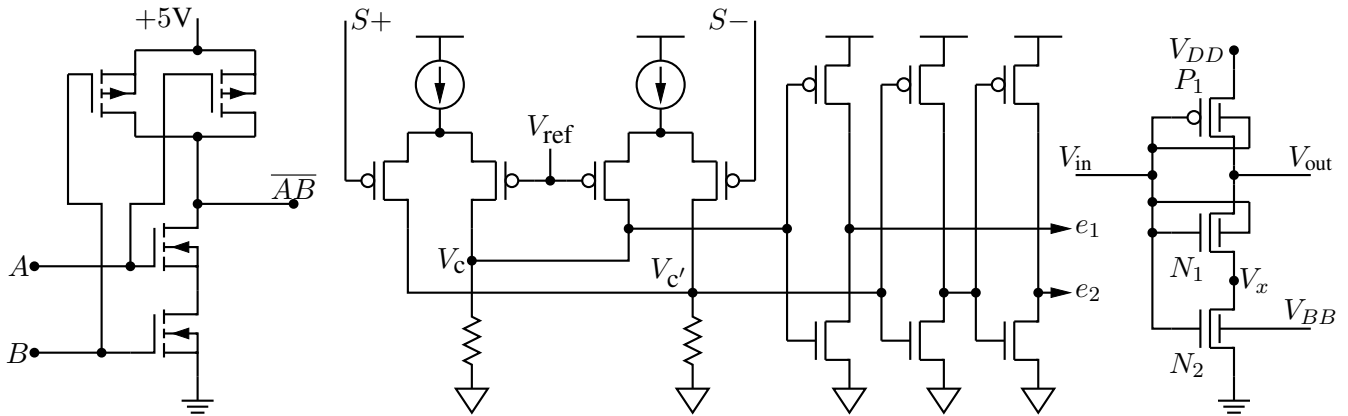

Figure 46: A CMOS NAND gate, a test circuit, and an XMOSEFET example [ex12.m4].

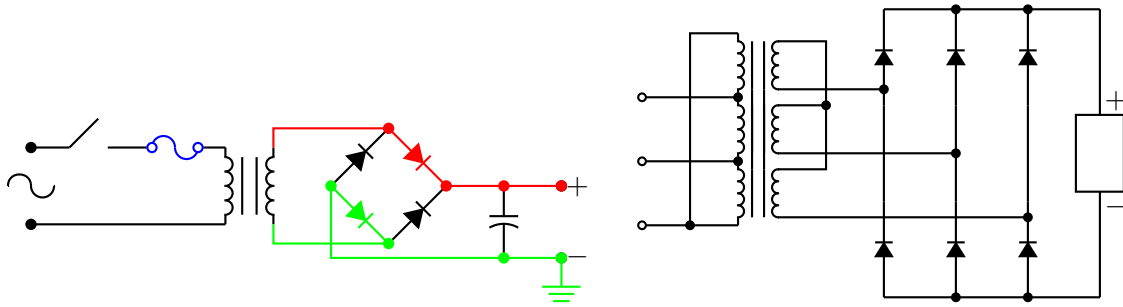

Figure 47: An elementary power supply circuit with colored elements, and a multiple-winding transformer with 3-phase rectifier [pwrsupply.m4].

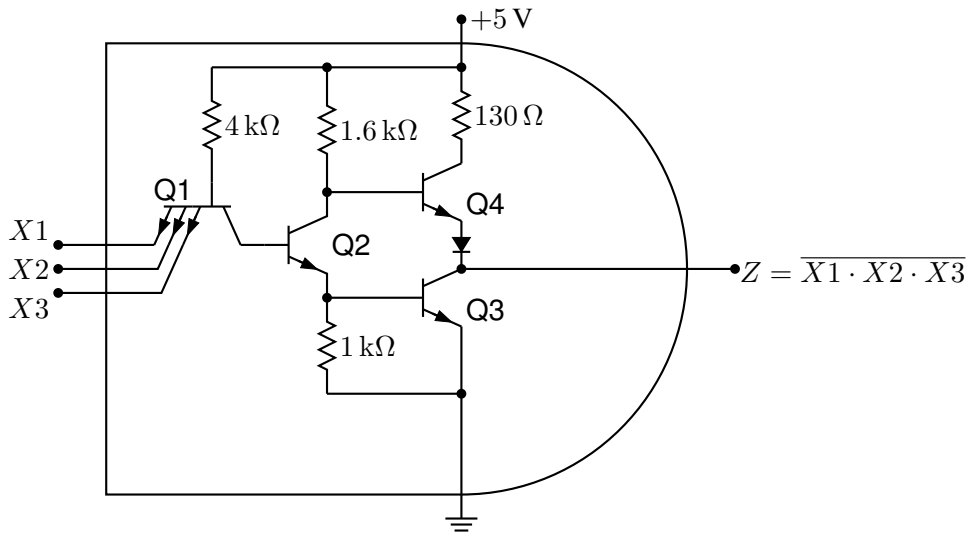

Figure 48: TTL NAND gate illustrating a transistor with multiple emitters [TTLnand.m4].

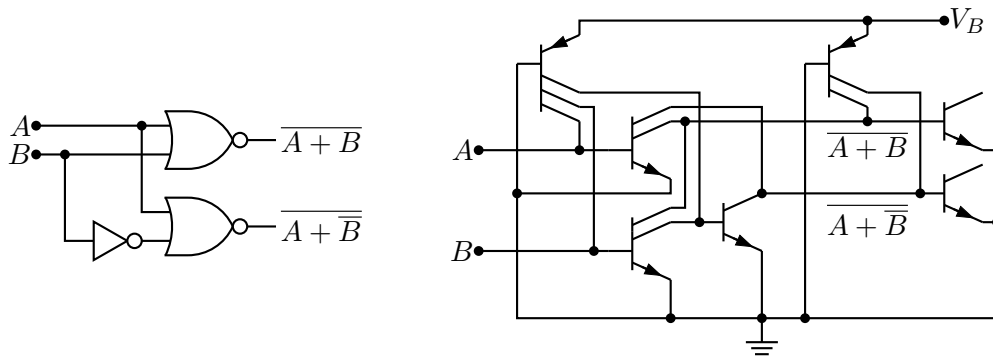

Figure 49: Gate circuit and equivalent embedded I^2L components illustrating multiple collectors [I2L.m4].

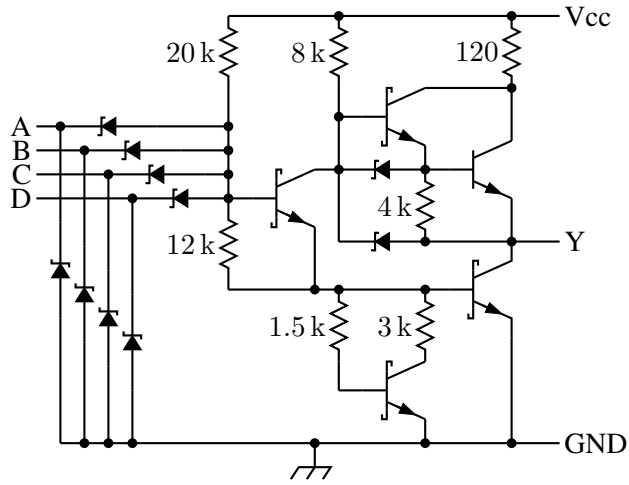

Figure 50: A 4-input NAND circuit illustrating the S (Schottky) option of `bi_trans` [Schottky.m4].

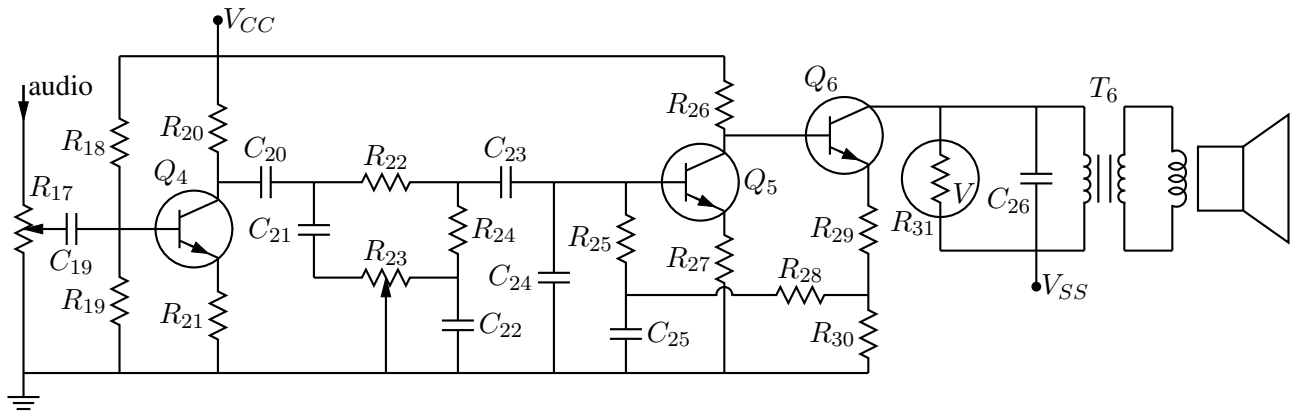

Figure 51: Transistor radio audio chain [ex11.m4].

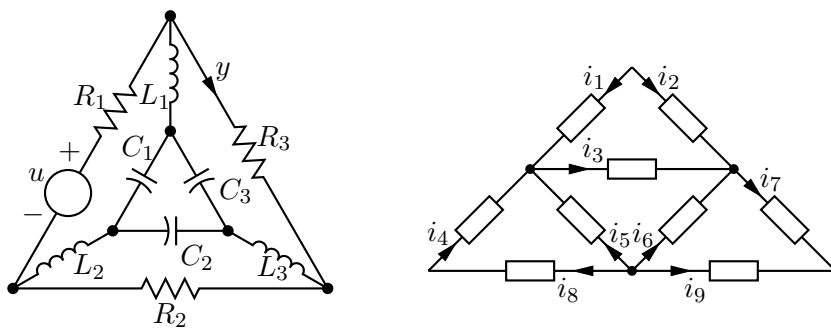

Figure 52: Labels on non-manhattan elements [ex04.m4].

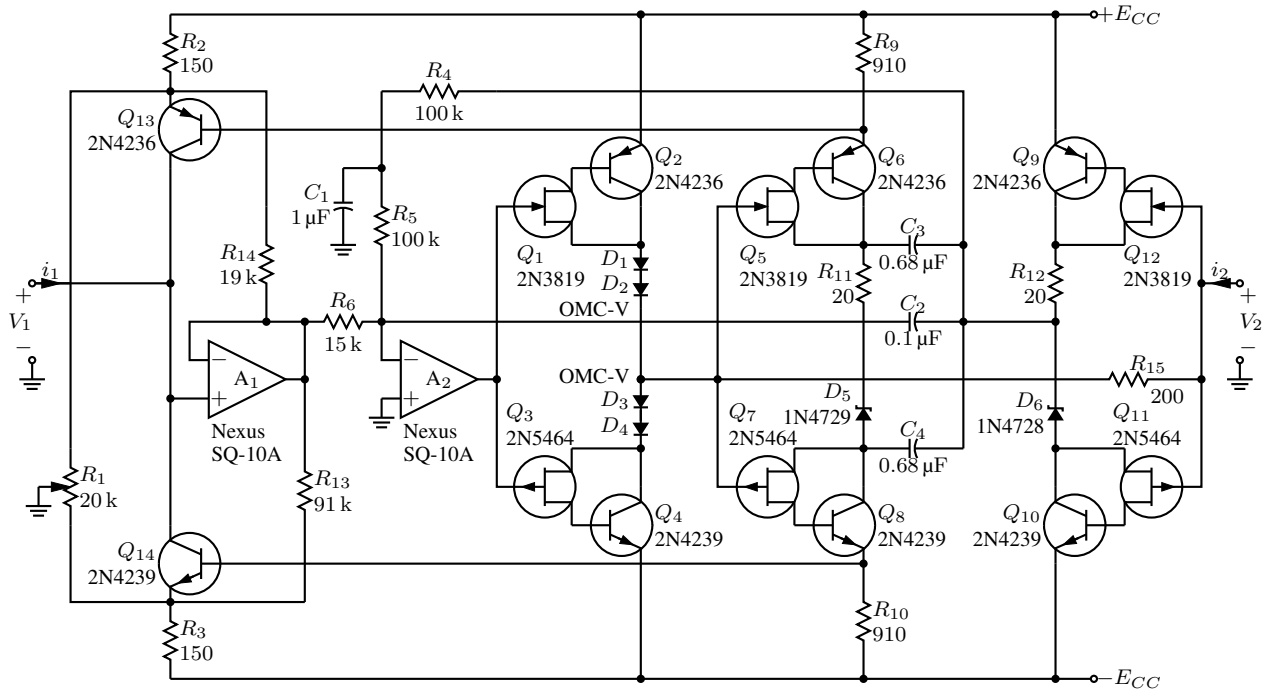

Figure 53: Realization of a controlled source (illustrating stacked element labels) [Csource.m4].

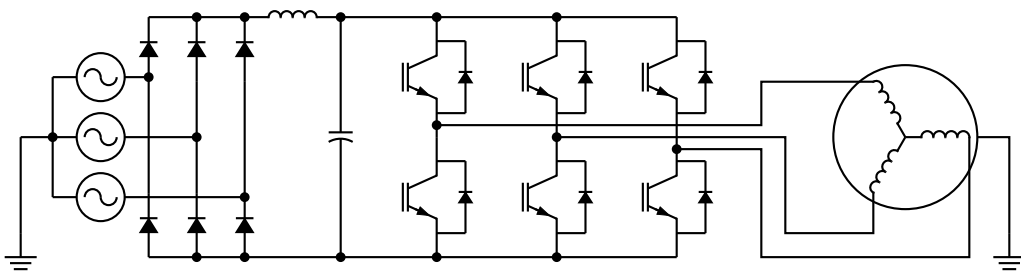

Figure 54: Synchronous machine driven by variable-speed drive and rectifier [Drive.m4].

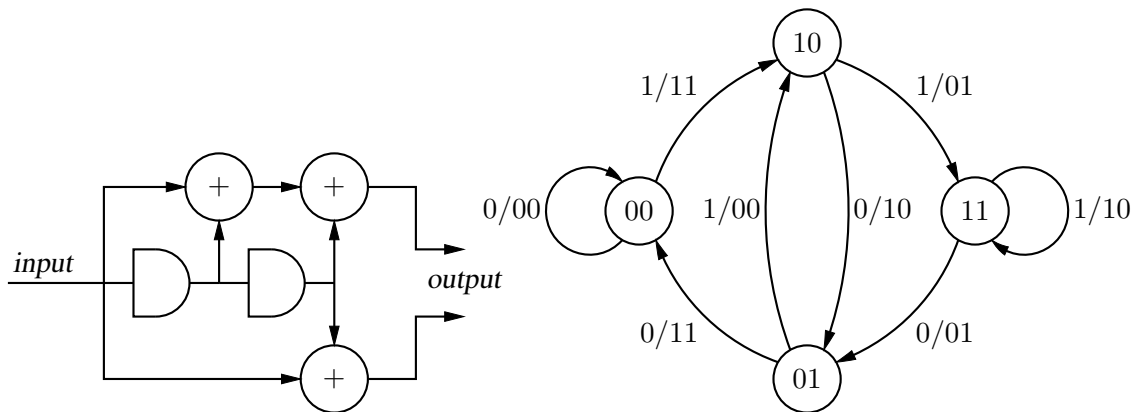

Figure 55: A rate 1/2 binary convolutional coder and its state diagram [ex16.m4].

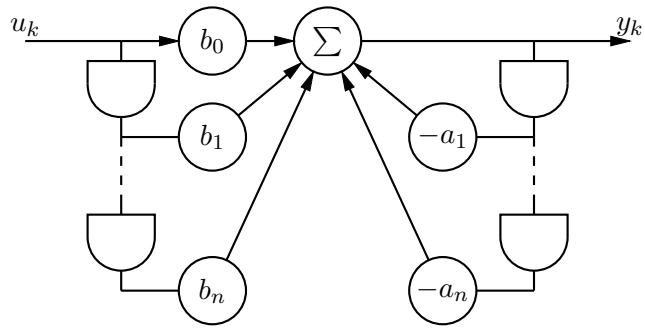

Figure 56: Digital filter [ex03.m4].

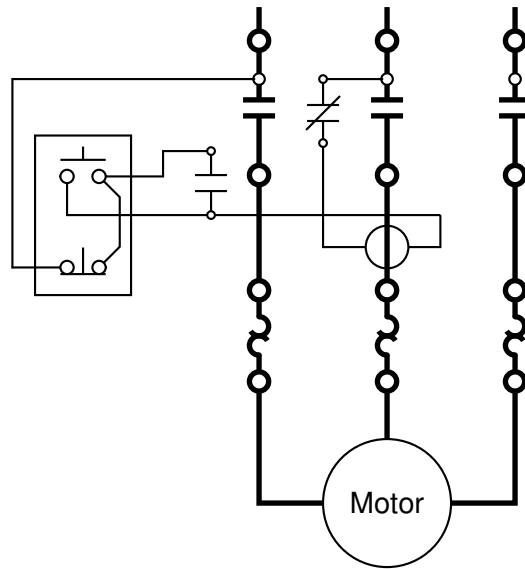

Figure 57: Motor control connections [MotorControl.m4].

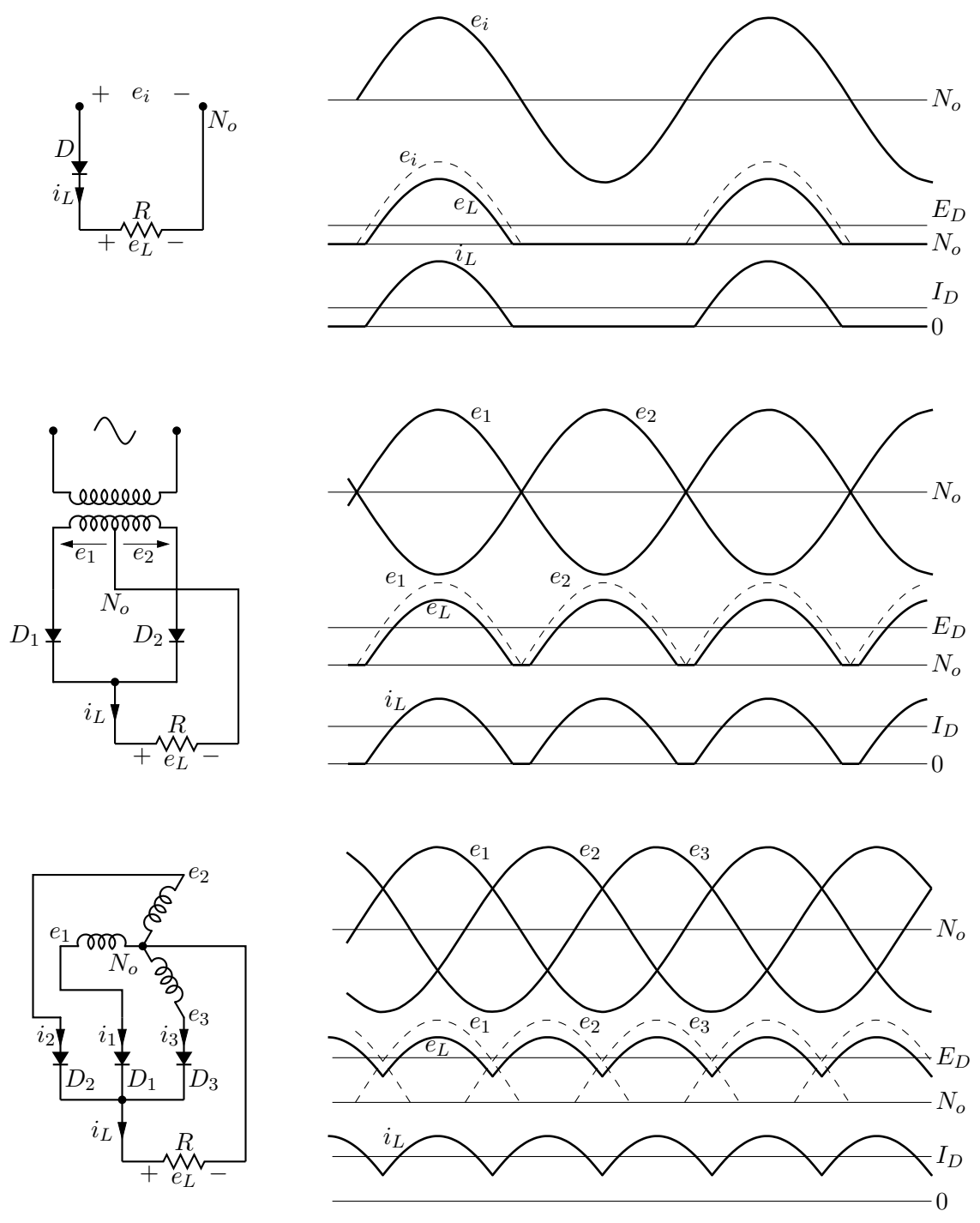

Figure 58: Rectifier circuits and waveforms [Rectifiers.m4].

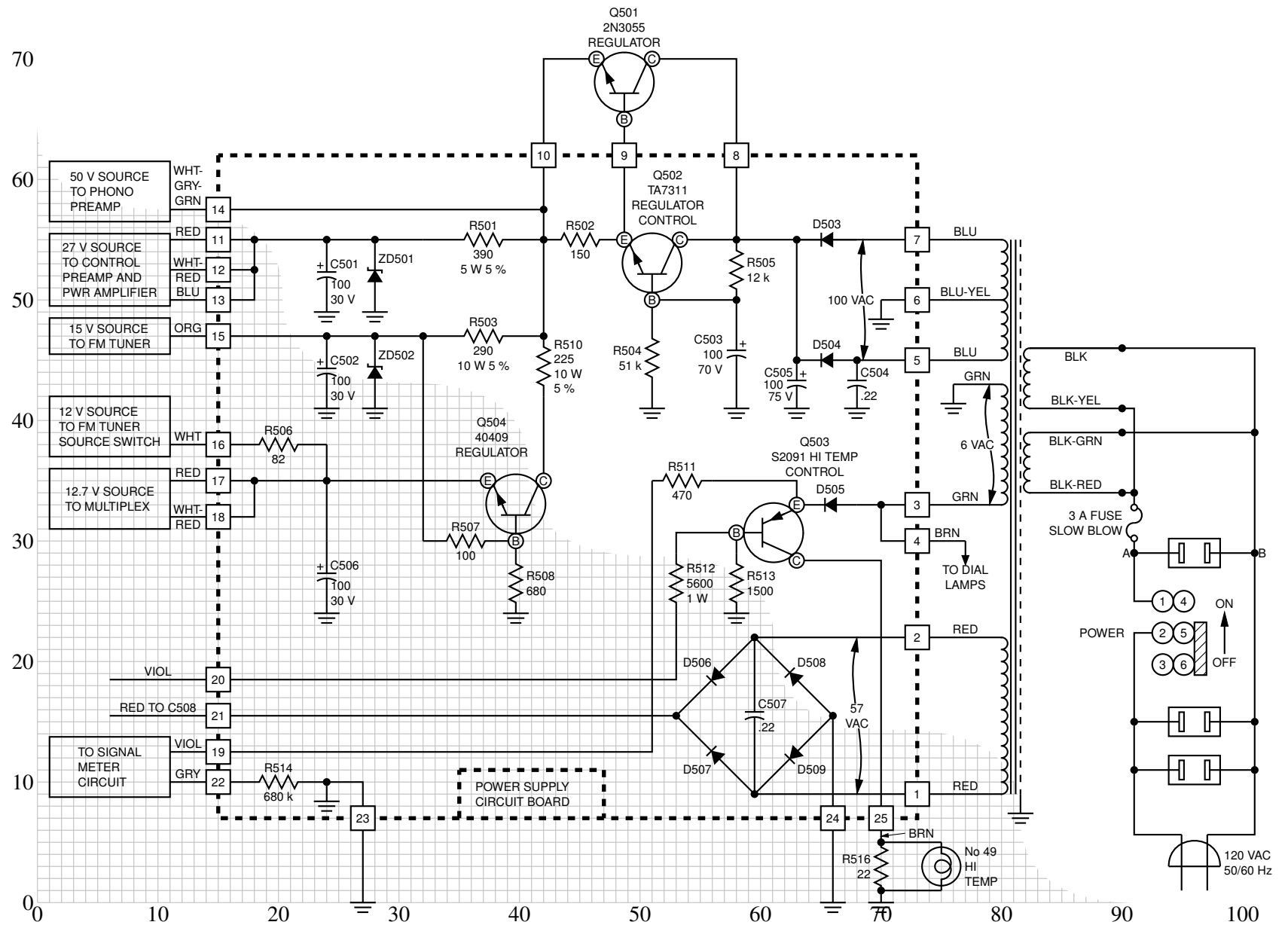

Figure 59: The power supply of a Heathkit AR-15 (Now, *that* was a receiver!) with custom transformer and other elements, drawn on a grid (partially shown) to aid in placement [Heathkit.m4].

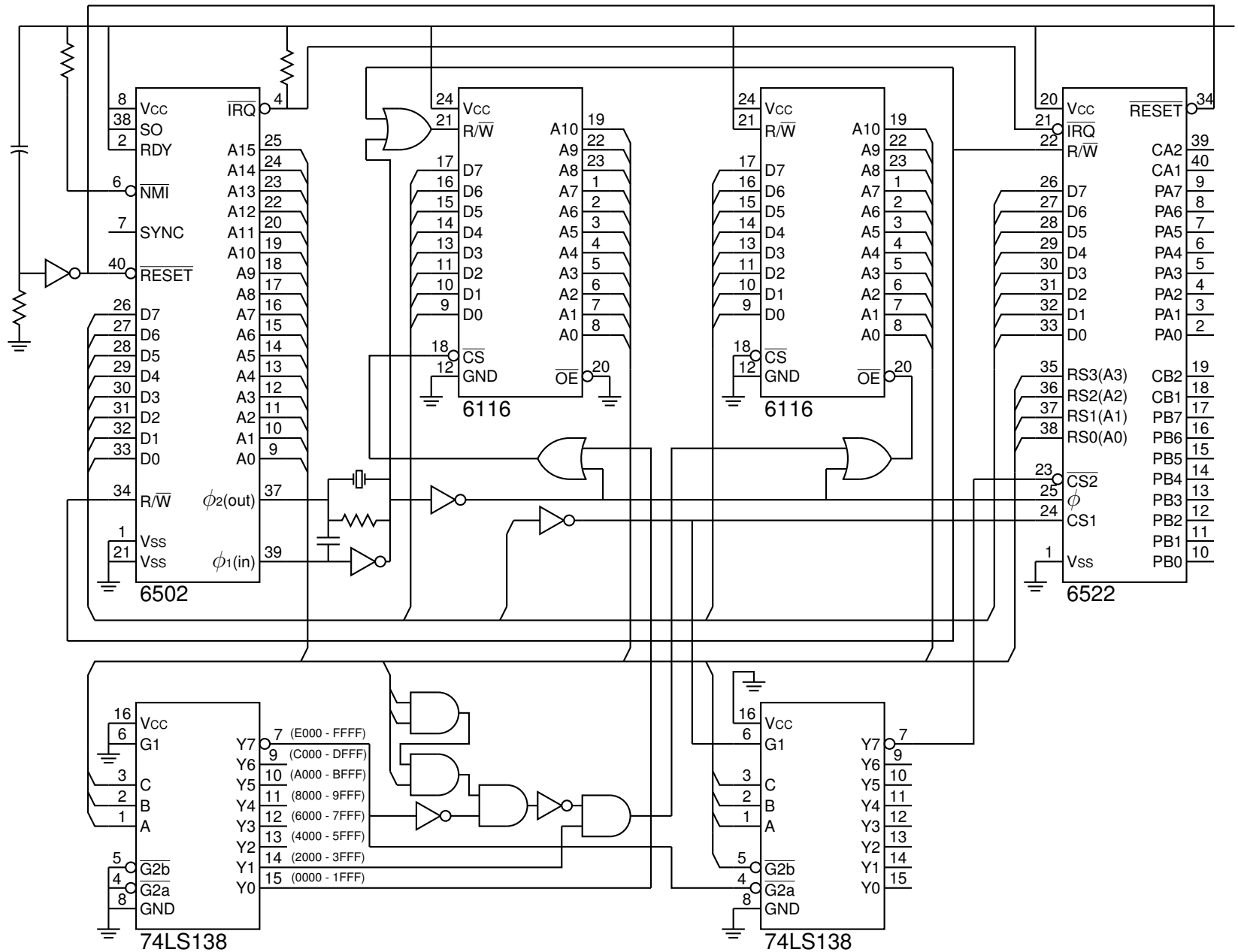

Figure 60: A digital circuit of moderate size, redrawn from M. P. Maclenan and G. M. Burns, "An Approach to Drawing Circuit Diagrams for Text Books," Tugboat (12)1, March 1991, pp. 66-69 [lcct.m4].

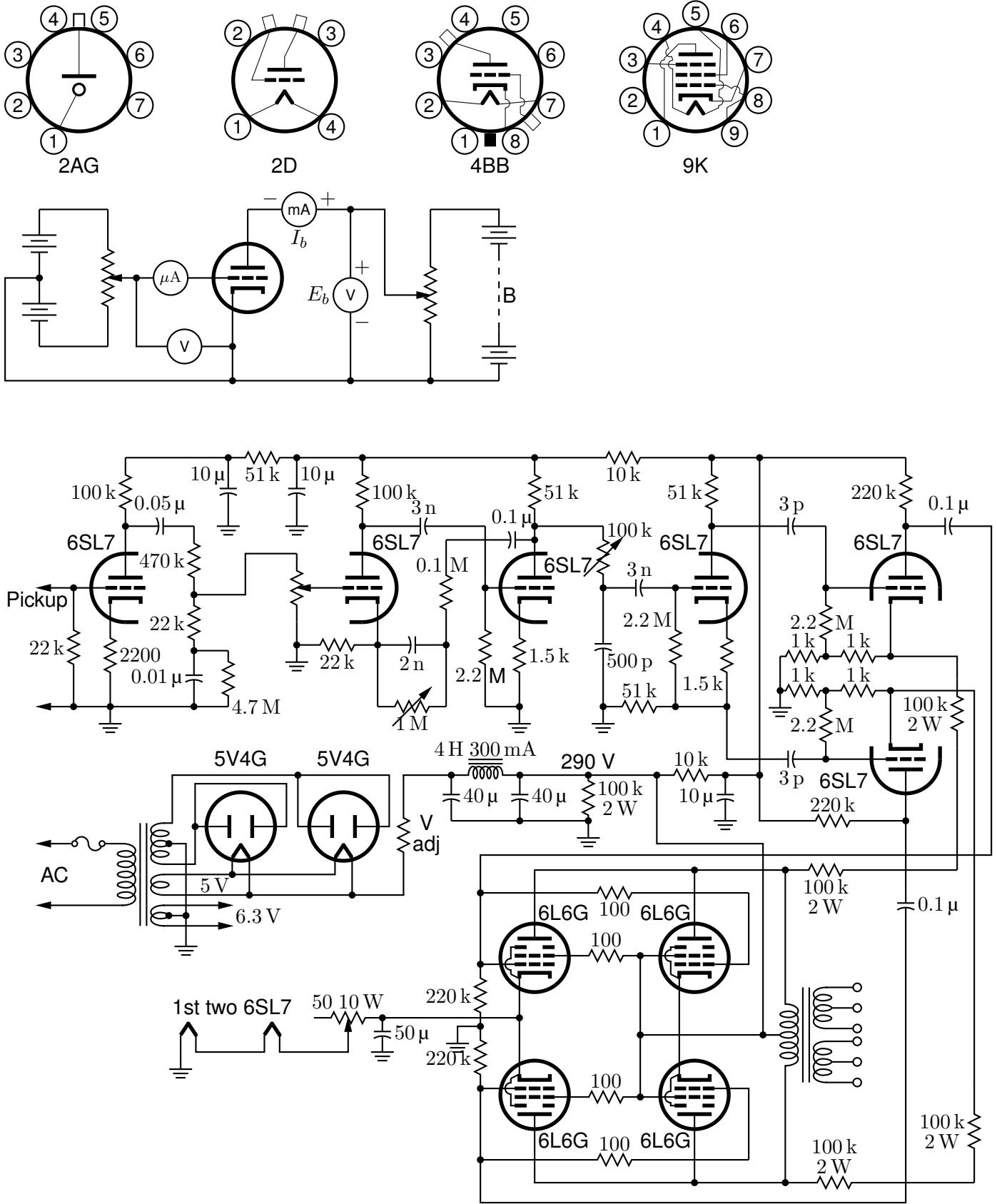

Figure 61: Electron-tube diagrams: a few bottom-view base diagrams, a generic triode test circuit, and a 25-watt audio amplifier adapted from F. Langford-Smith, *Radiotron Designer's Handbook*, fourth edition, Harrison, NJ: Radio Corporation of America, 1952 [Tubediags.m4].

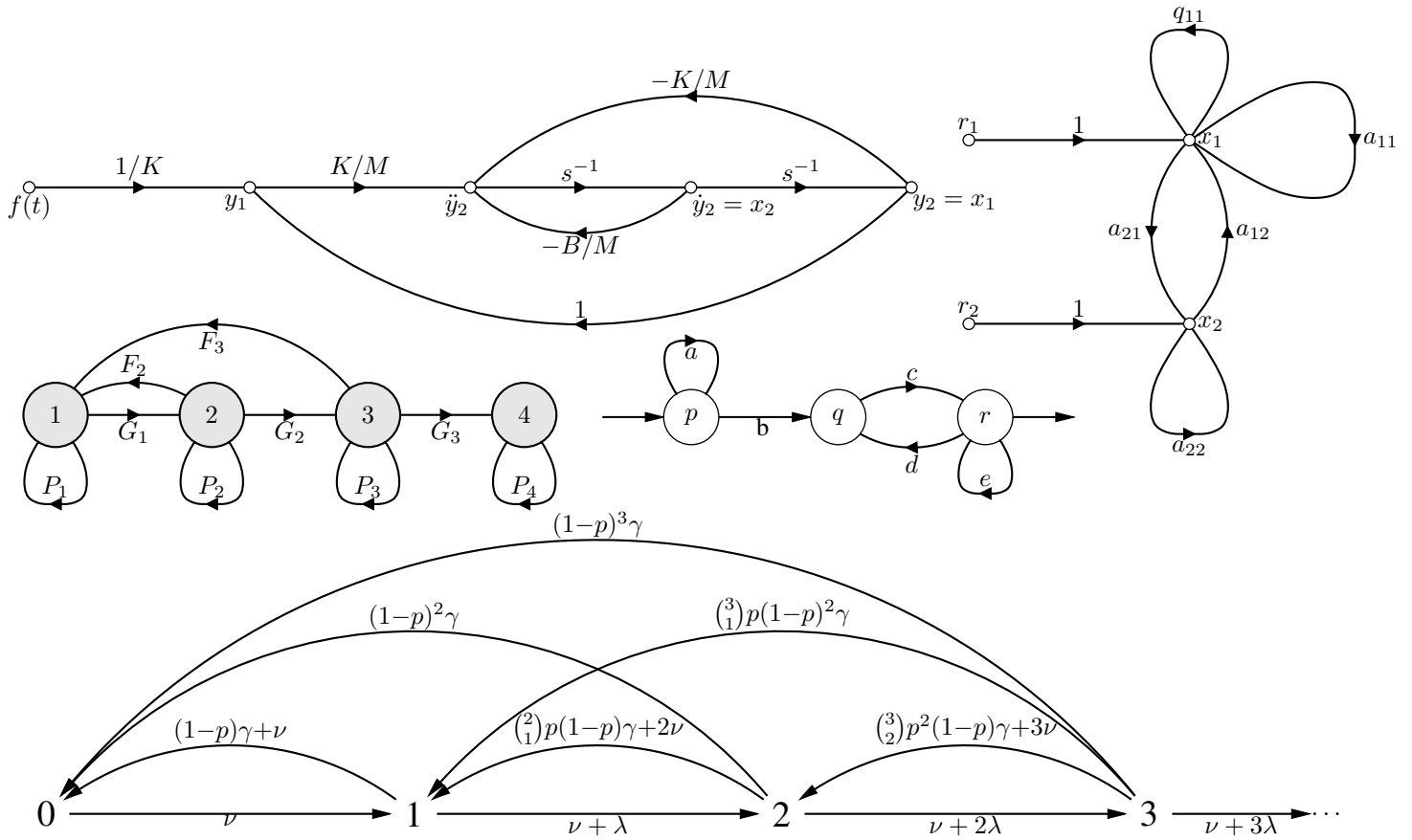

Figure 62: Signal-flow graphs [sfg.m4].

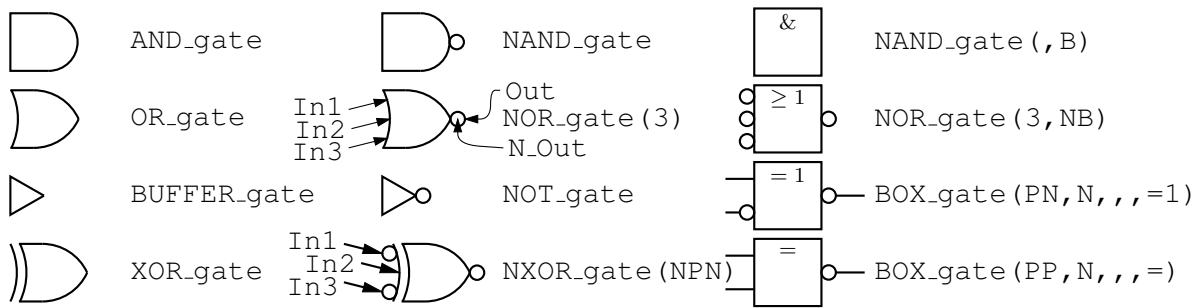

Figure 63: Basic logic gates [Logic.m4].

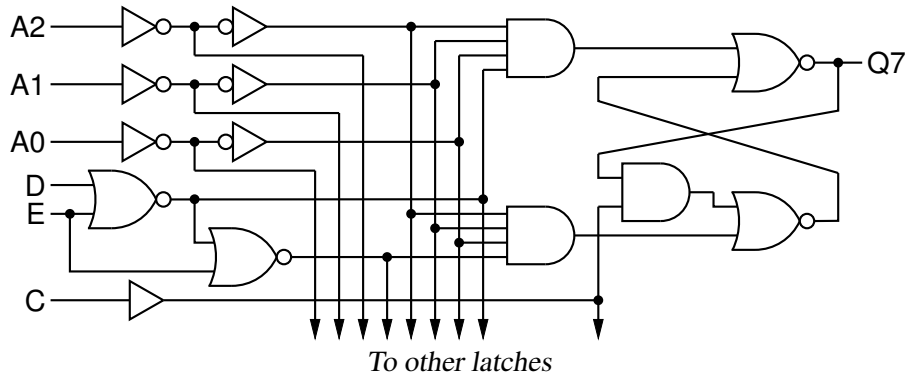

Figure 64: General-purpose latch: a small logic circuit [ex08.m4].

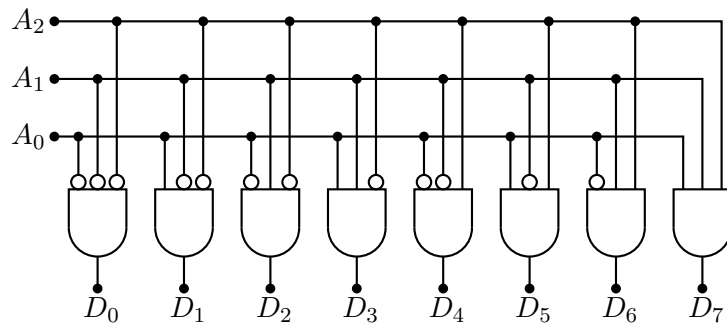

Figure 65: Decoder logic, constructed using the for_macro [Decoder.m4].

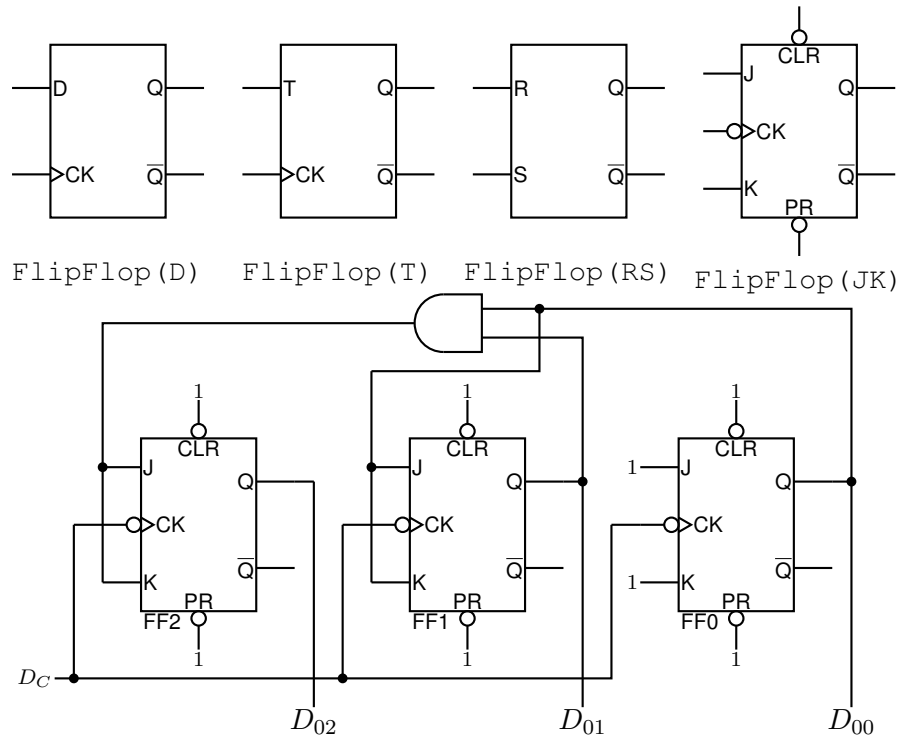

Figure 66: Some flip-flops [ex21.m4].

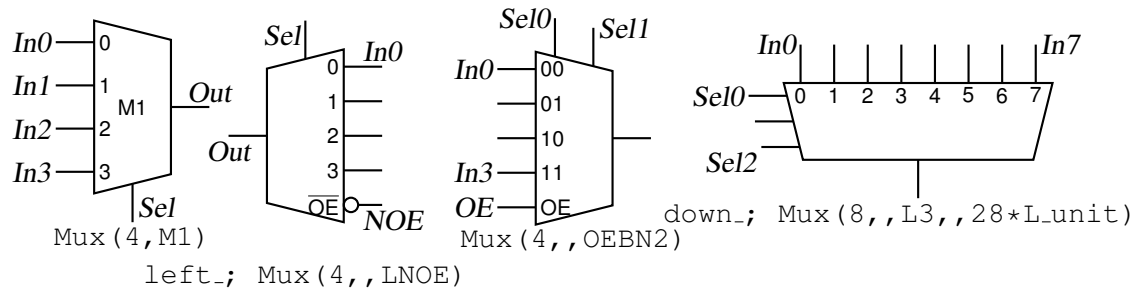

Figure 67: Multiplexer [Multiplexer.m4].

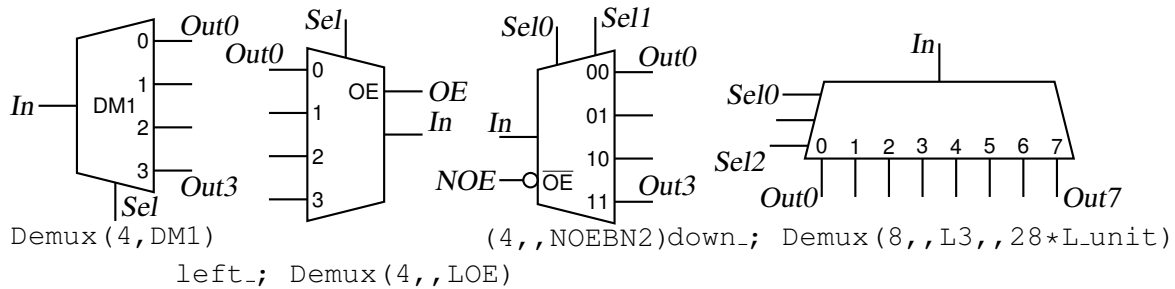

Figure 68: Demultiplexer [Demultiplexer.m4].

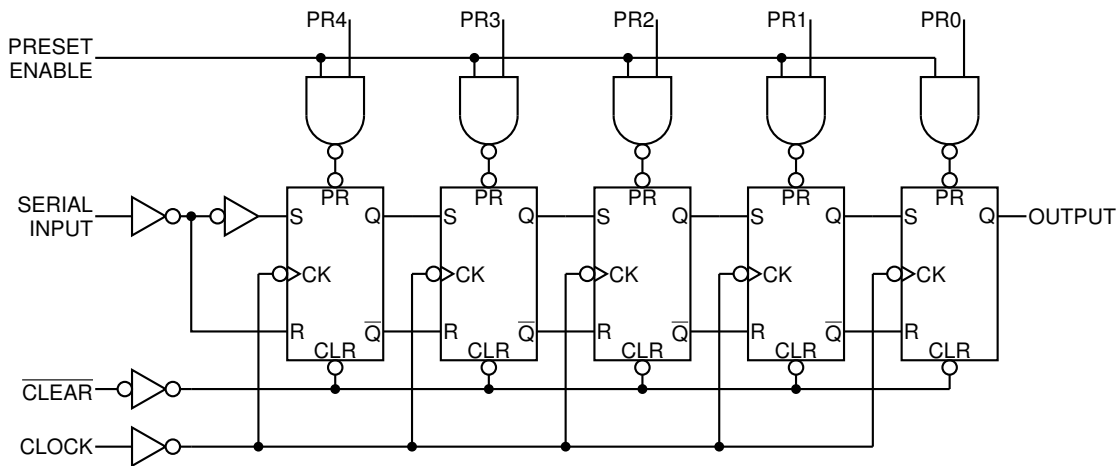

Figure 69: A 5-bit shift register drawn using a custom flip-flop [ShiftR.m4].

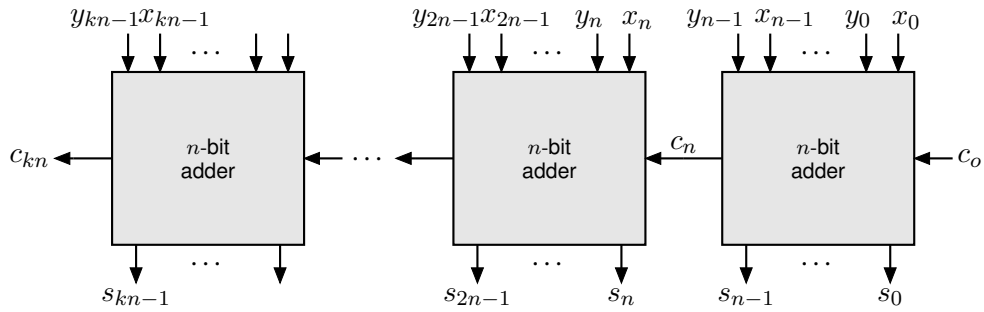
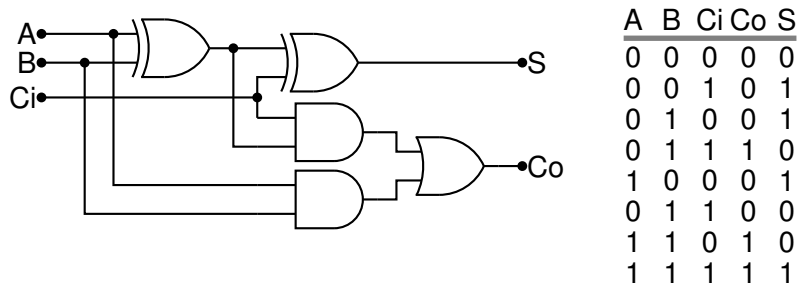
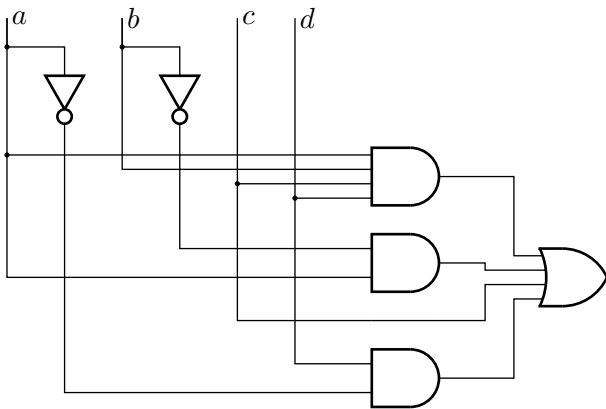
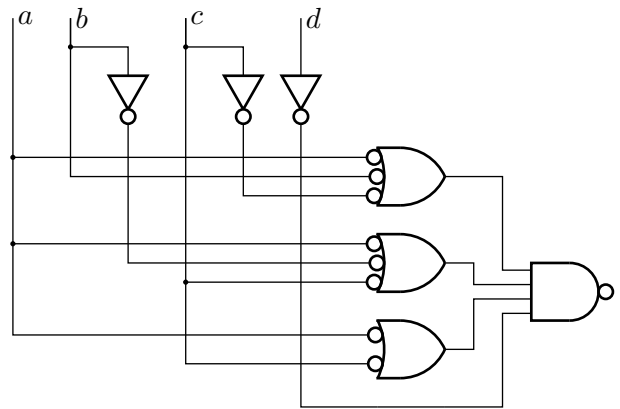

Figure 70: A full adder and a cascade of n -bit adders [Adder.m4].



CanLogic (AND, OR, abcd, ~ba, c, d~a)



CanLogic (OR, N, NAND, ab~c, a~bc, ac, ~d)

Figure 71: A way of automatically drawing two-layer logic diagrams [CanLogic.m4].

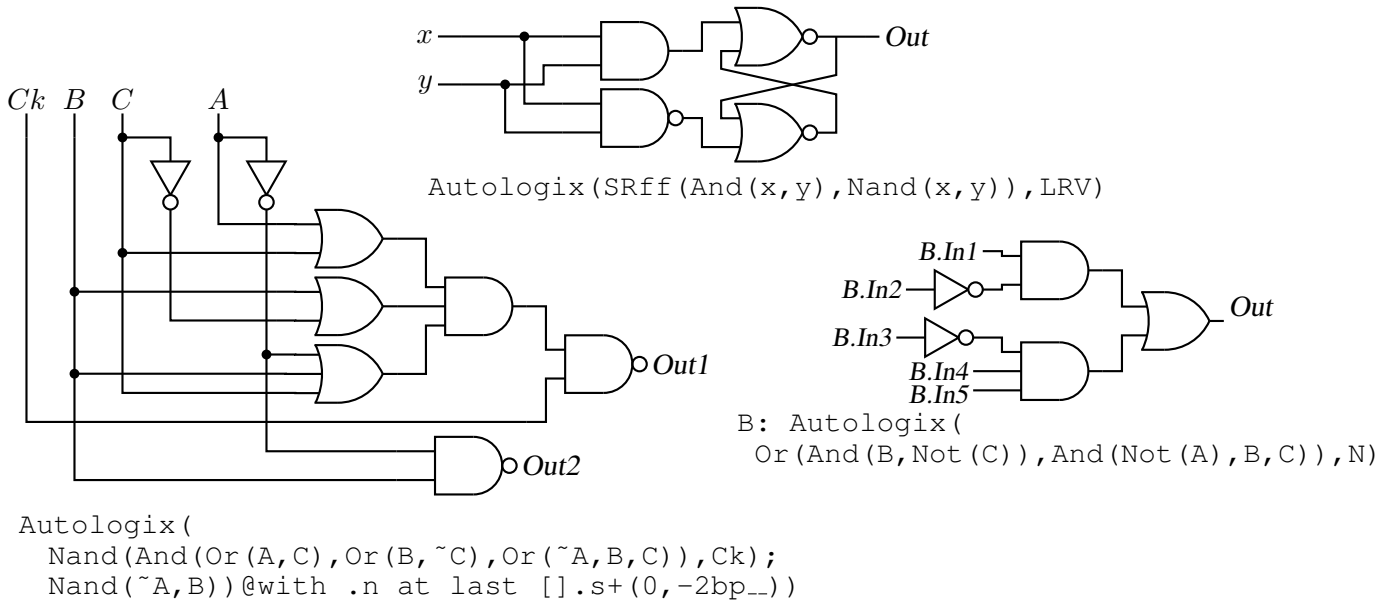
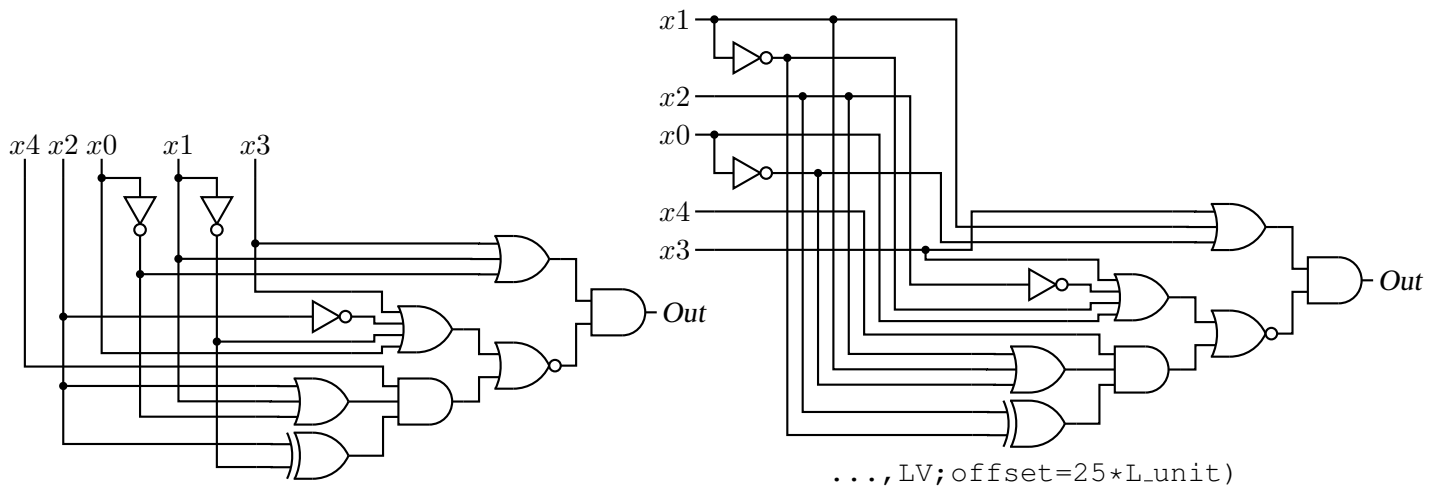

Figure 72: The `Autologix(Boolean expression; Boolean expression... , options)` macro automatically draws Boolean expressions in function notation. The function tree is drawn, then a row or column of inputs, then the connections. The default result is on the left, a custom element at the top, and a tree of gates only is shown on the right. The lower examples illustrate the L, R, and V options.) [Alogix.m4].



```
Autologix (And (Or (x3, x1, ~x0),
  Nor (Or (x3, Not (x2), ~x1, x0), And (x4, Or (x2, x1, ~x0), Xor (x2, ~x1))))))
```

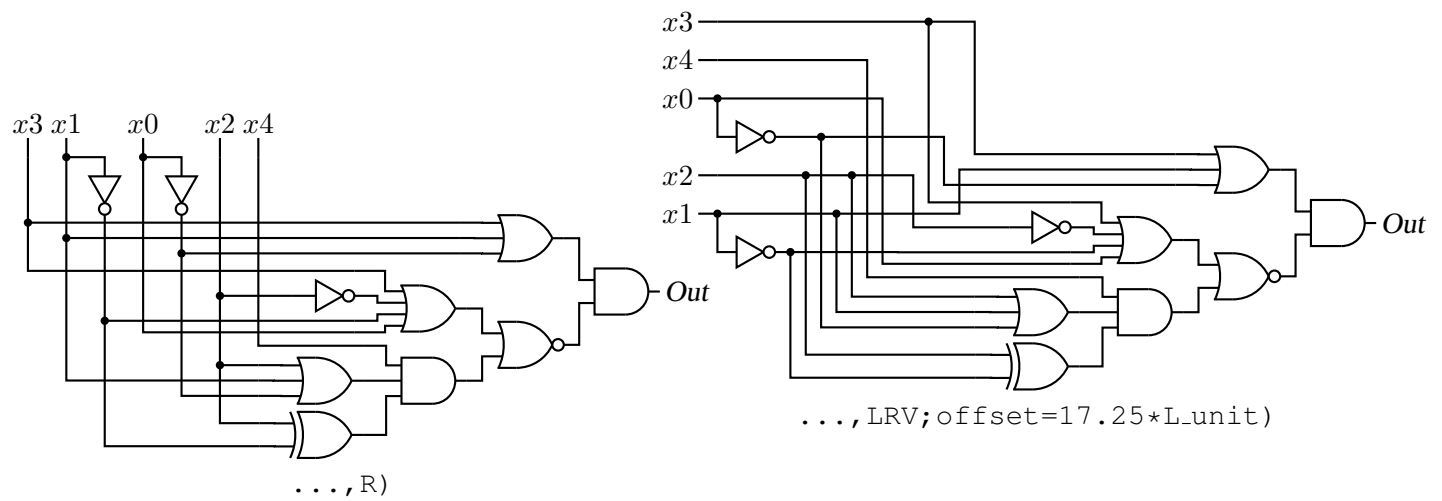

Figure 73: The Autologix macro can draw inputs on the left but the added drawing complexity may require hand tuning with second-argument options: L puts the inputs on the left, R reverses their order, V scans the input arguments in reverse order, and offset=value displaces the array of inputs [ABlogix.m4].

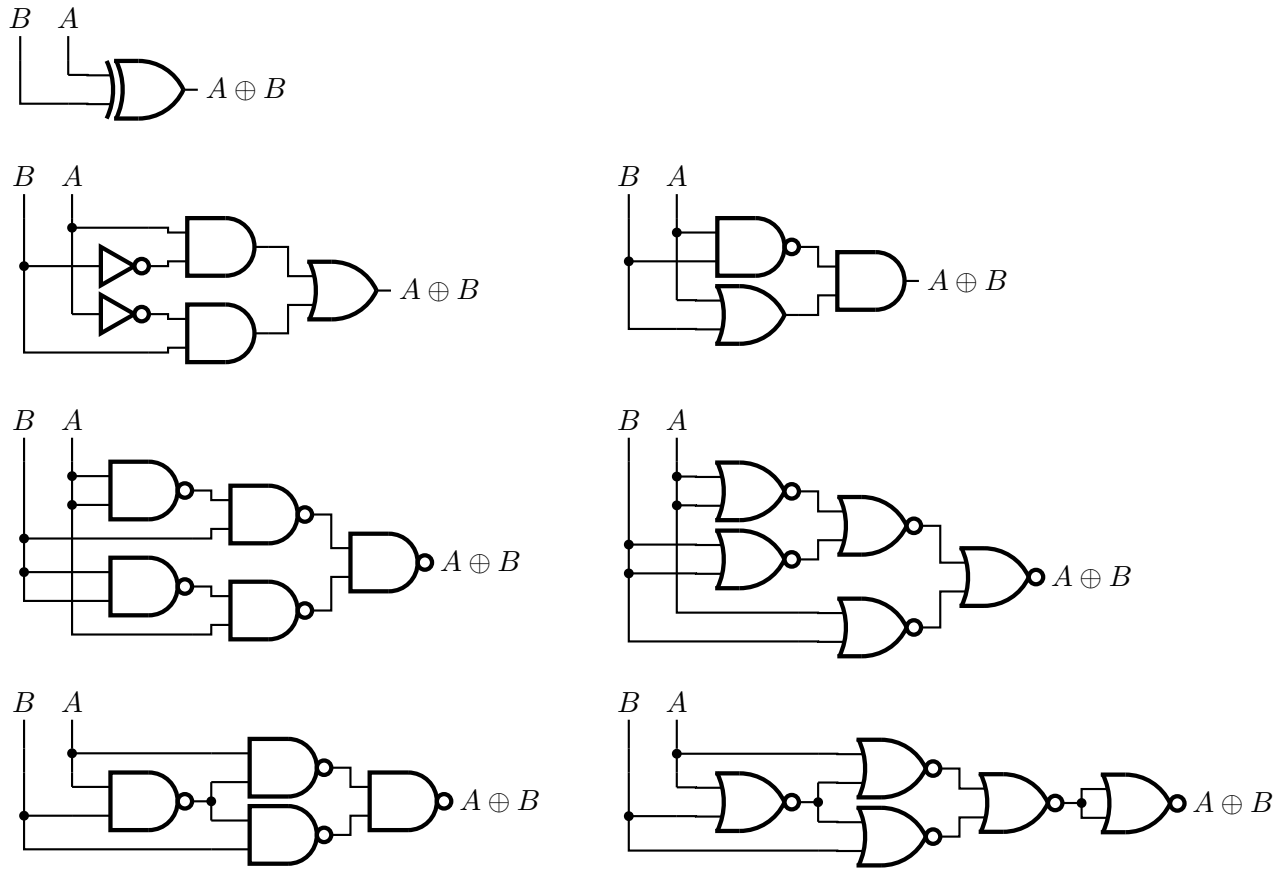

Figure 74: Realizations of the XOR function using Autologix [XOR.m4].

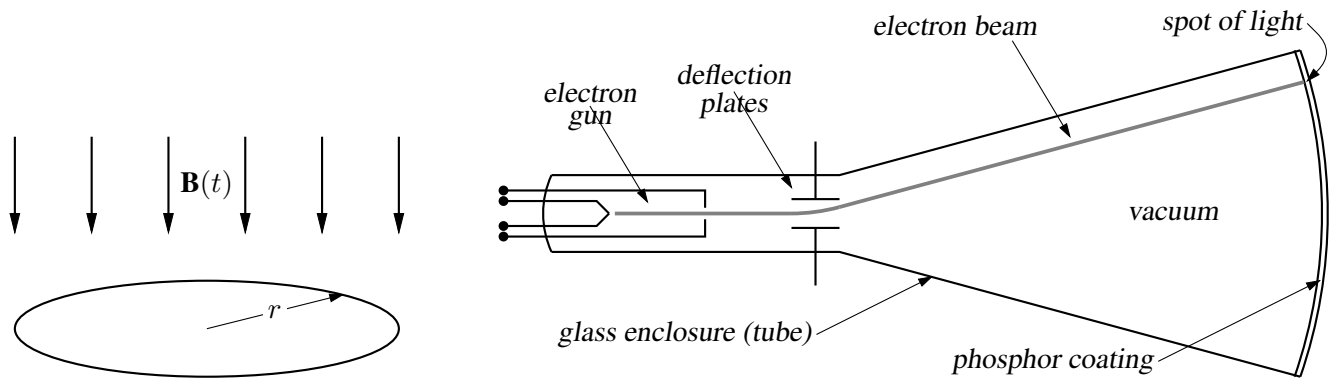
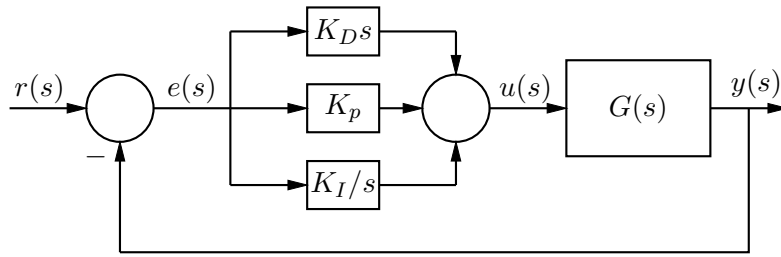
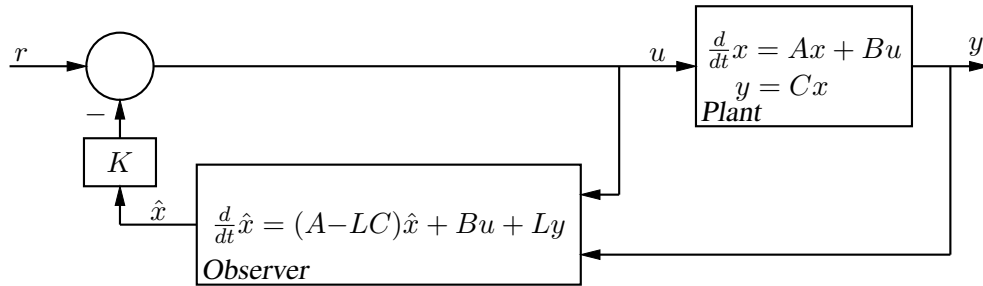

Figure 75: Line diagrams [ex00.m4].



(a) *PID* control



(b) Output feedback with a full-order observer

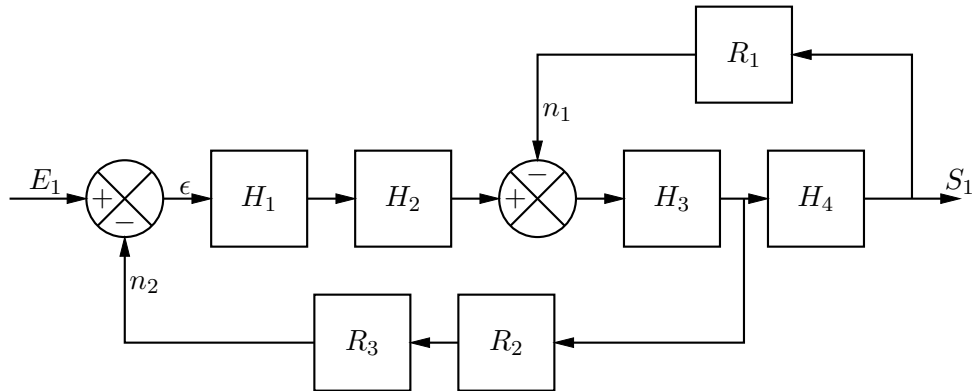

(c) A multiblock example

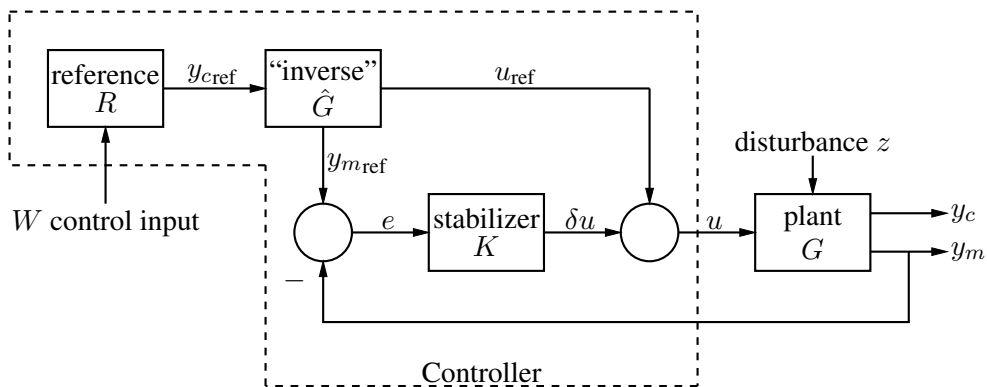

(d) Nonlinear feedforward (for performance) and small-signal feedback (for stability)

Figure 76: Control-system block diagrams that do not require `m4 [control.m4]`.

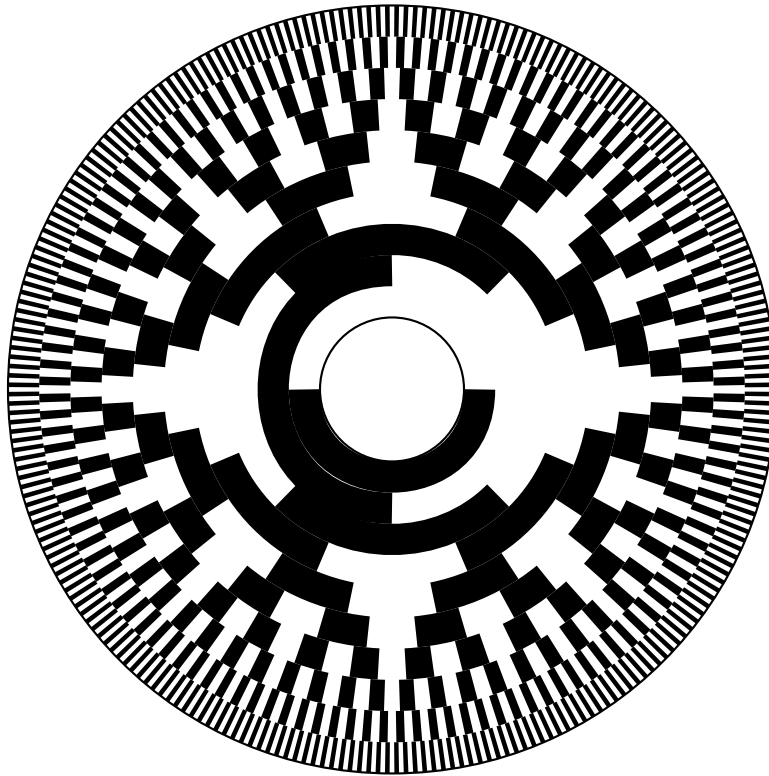

Figure 77: Gray code 10-bit encoder disk pattern [GrayCode.m4].

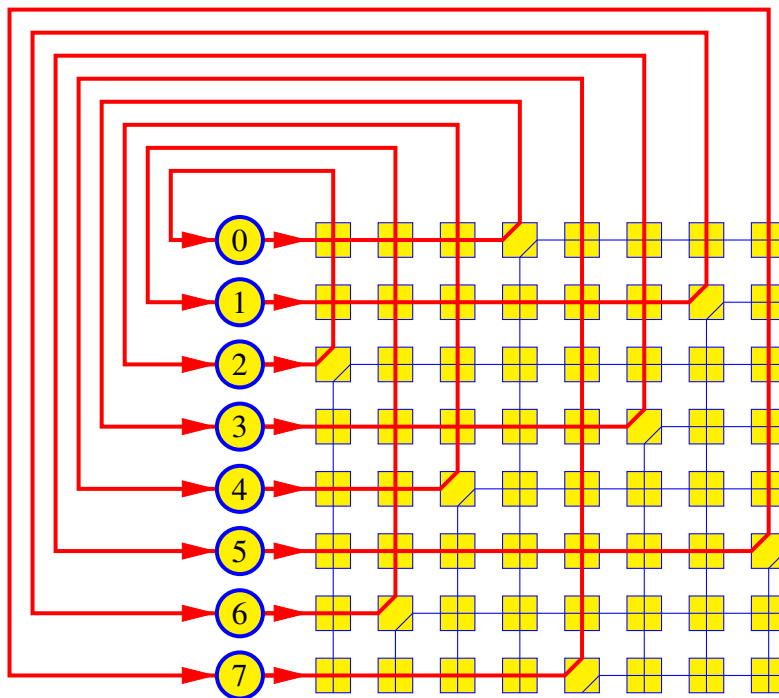

Figure 78: A crossbar switch [Crossbar.m4].

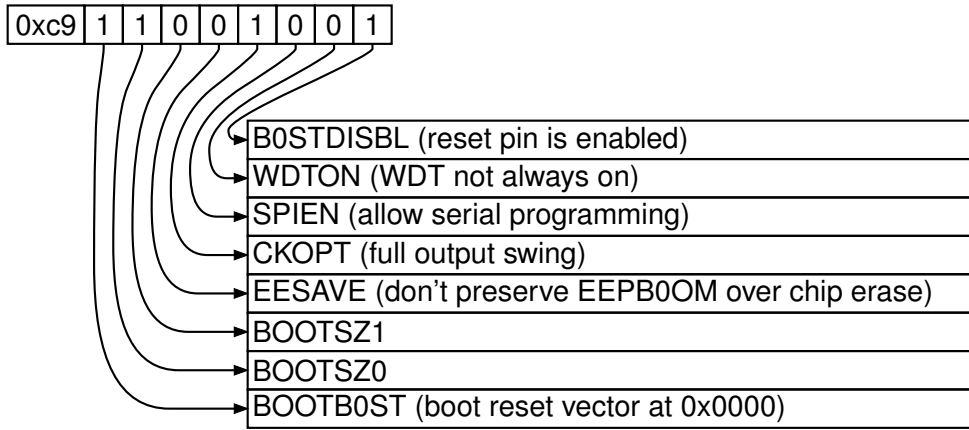

Figure 79: Elementary splines [Byte.m4].

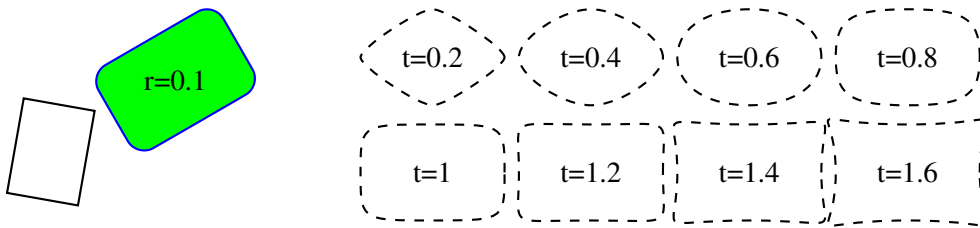

Figure 80: The macro `rotbox (wid,ht,type,[r|t=val])` draws a box in the current direction [Rotbox.m4].

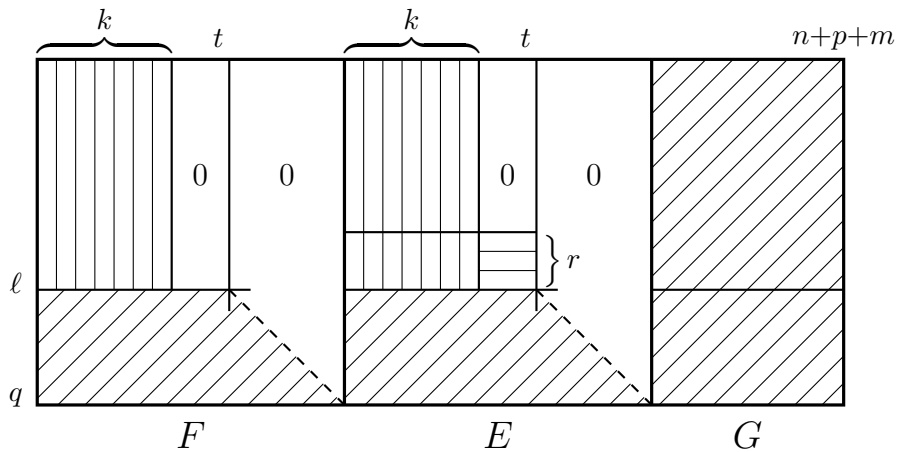
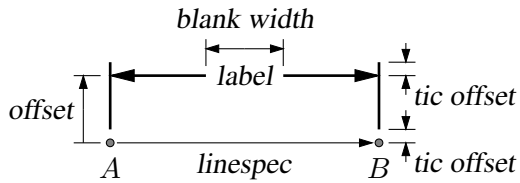
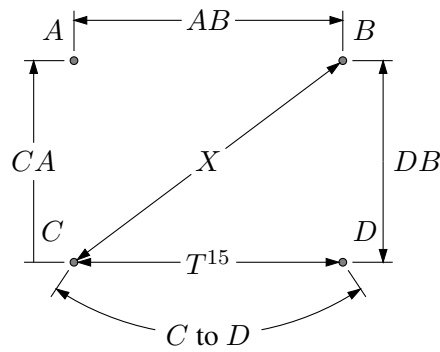
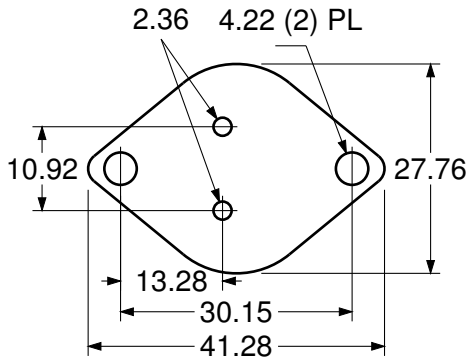

Figure 81: Crosshatching by for loops [ex06.m4].



```

dimension_(from A to B,0.3,$AB$,20bp_)
dimension_(from C to B,,,$X$,16bp_)
dimension_(from C to A,0.3,$CA$,14bp_,-,->)
dimension_(from D to B,-0.3,"$DB$" ljust)
dimension_(from C to D,,s_box($T^{%g}$,15),W)
arcdimension_(from C to D with .c at \
0.5 between A and B,12bp_-,s_box($C$ to $D$),W)

```

```
dimension_(from A to B,0.5,\sl label,29bp_-,0.1)
```

Figure 82: Illustrating the macro `dimension_(linespec, offset, label, D|H|W|blank width, tic offset,<-|->)`. A negative second argument implies an offset to the right of the `linespec` direction. A `label` starting with `"` or `sprintf` is copied literally. If `label` is an `s_box(...)` then setting argument 4 to `H`, `W`, or `D` tailors the blank width to the `s_box` height, width, or diagonal respectively; i.e., `W` is equivalent to `s_wd+textoffset*2`. The macro `arcdimension_` is similar but the first argument specifies the arc to be dimensioned and the second argument is the outward radial offset of the dimension arrow arc. [ex09.m4].

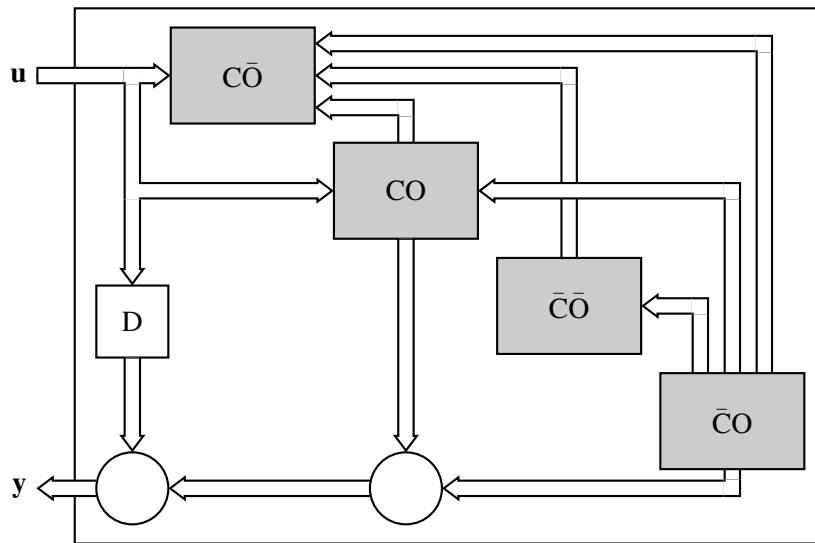

Figure 83: Use of `darrow` [ex05.m4].

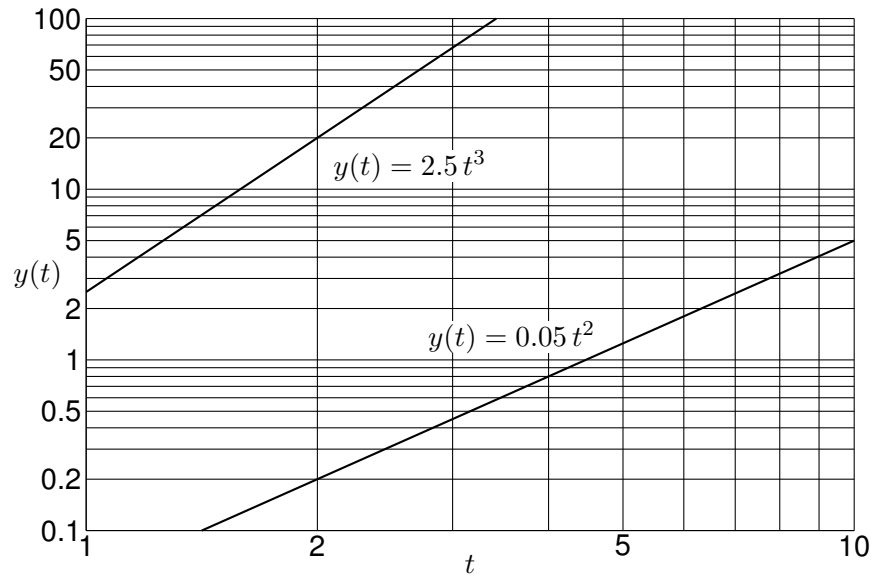

Figure 84: A graph drawn using the pic language [Loglog.m4].

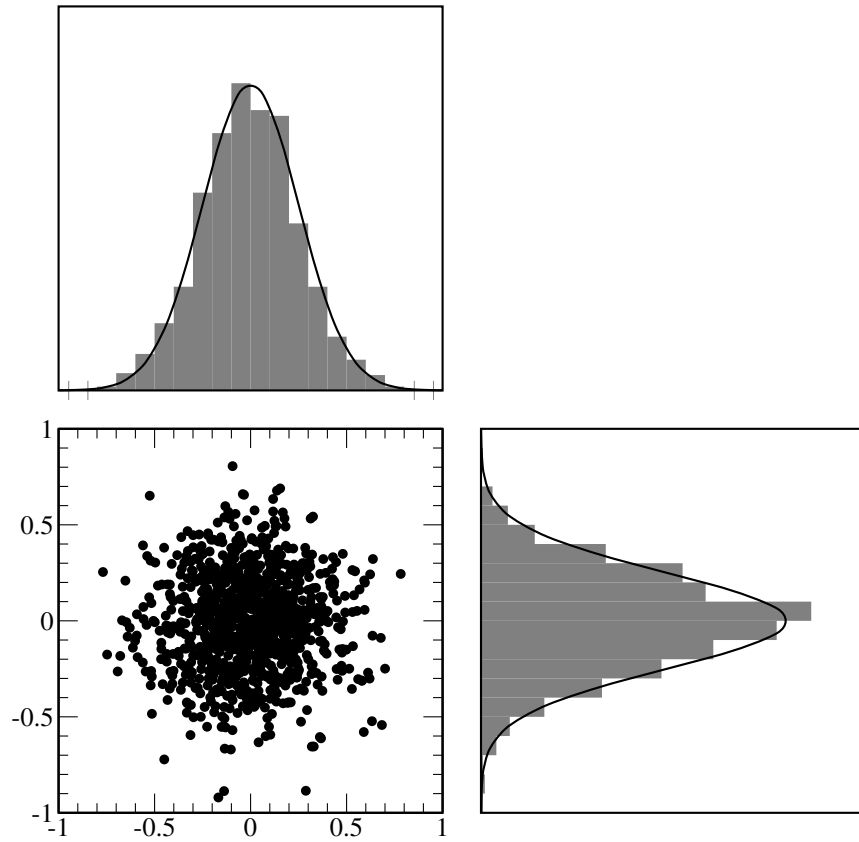

Figure 85: Testing random number generation [random.m4].

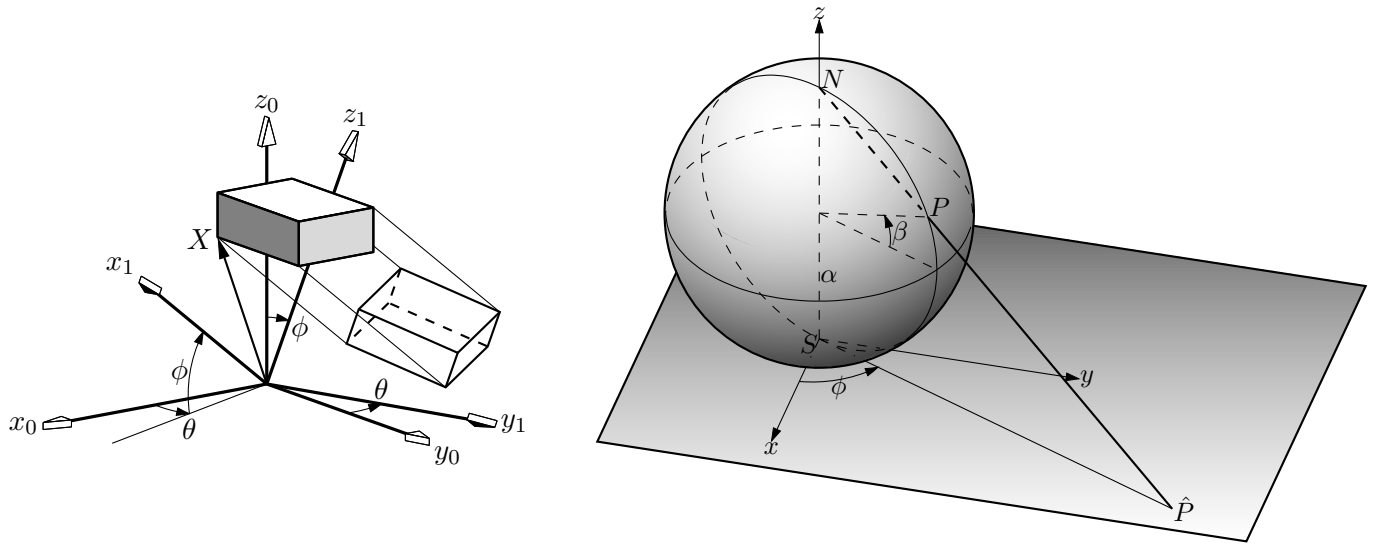

Figure 86: Test of `project` and other `lib3D` macros, showing the projection of a solid onto the y_1, z_1 plane by sighting along the x_1 axis. [`exp.m4`].

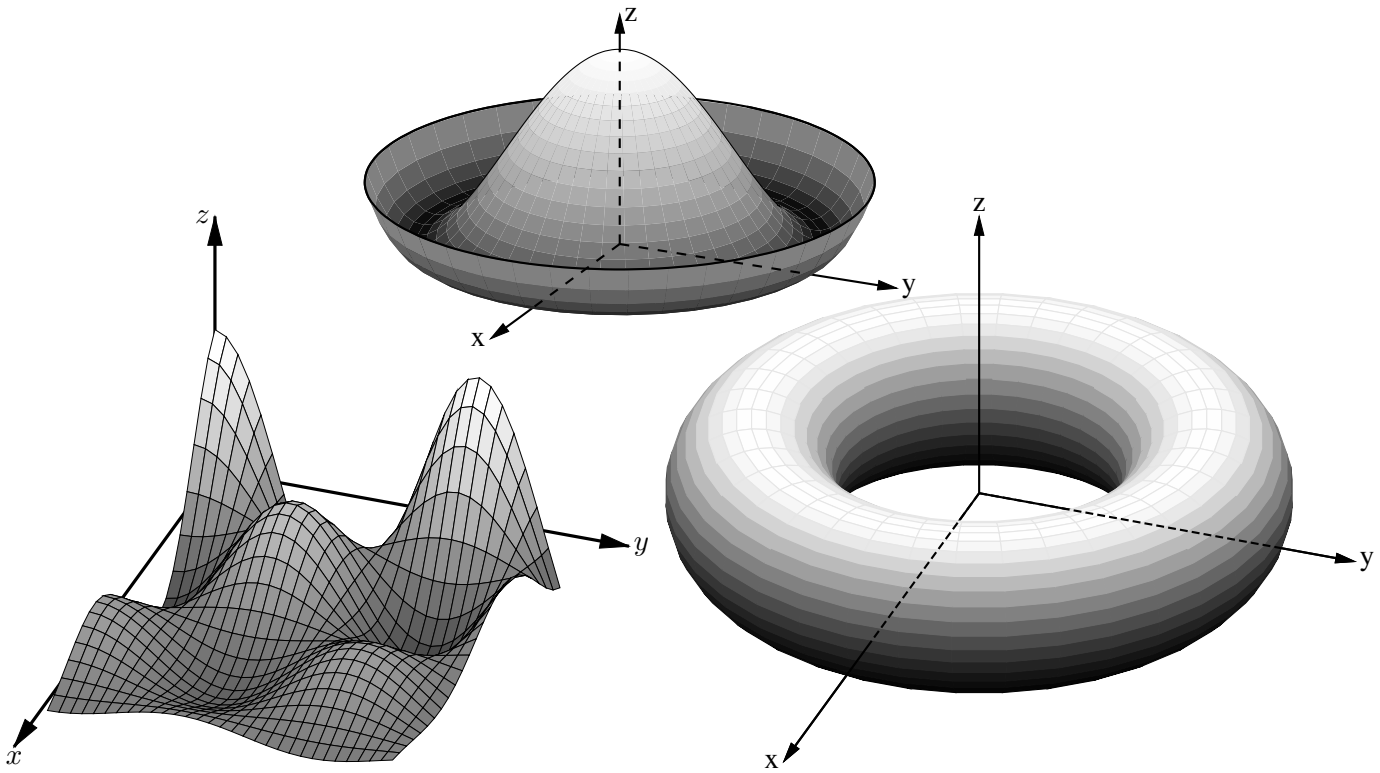

Figure 87: Plotting surfaces using gray scales. A sort algorithm determines plotting order [`graysurf.m4`].

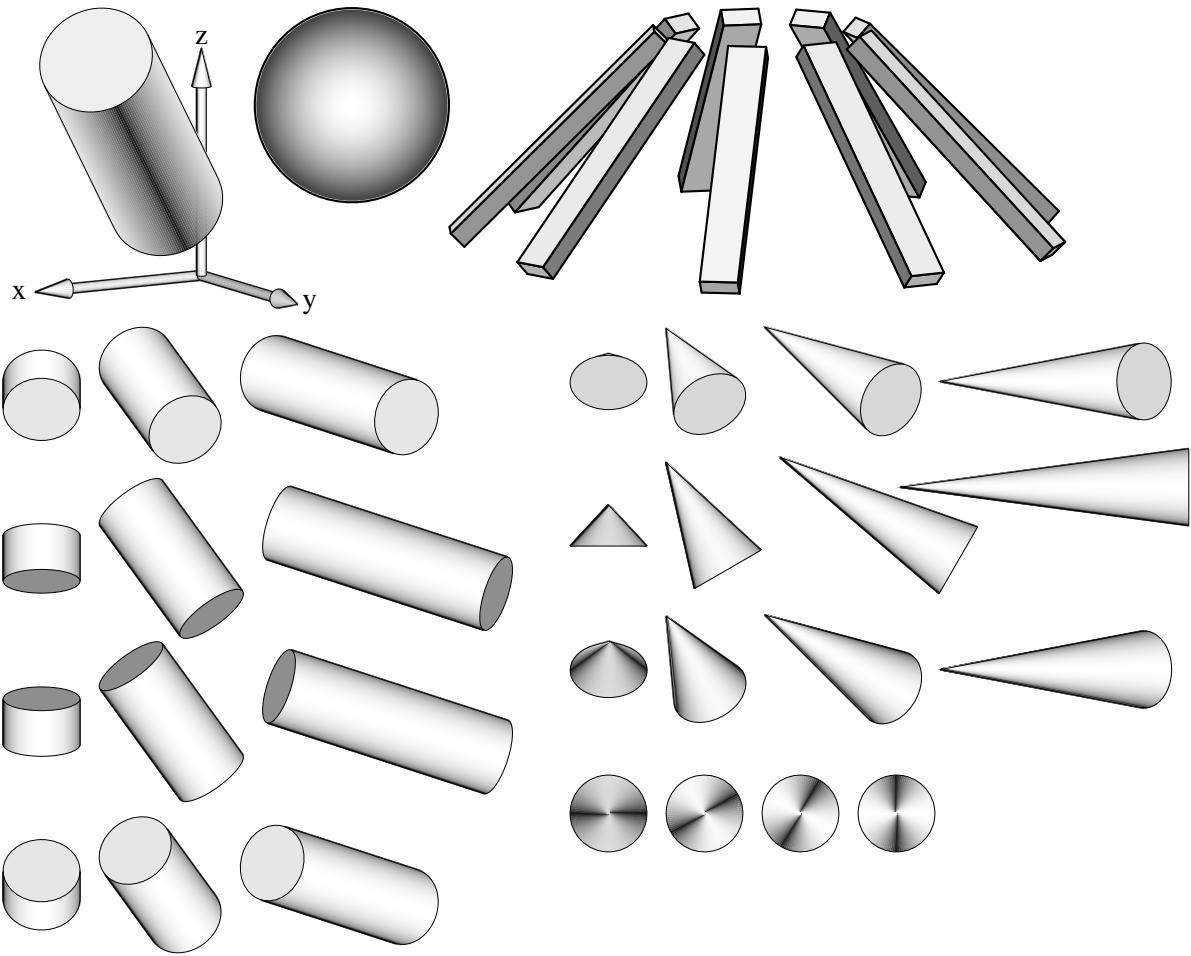

Figure 88: Basic shapes [shapes.m4].

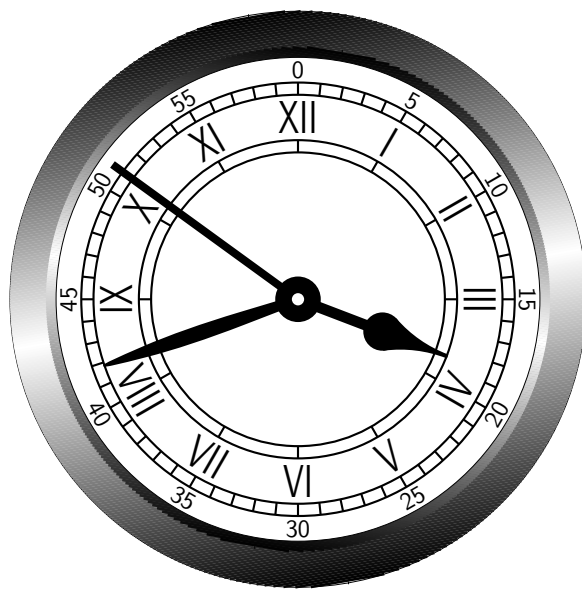

Figure 89: An antique clock face [AntiqueClock.m4].

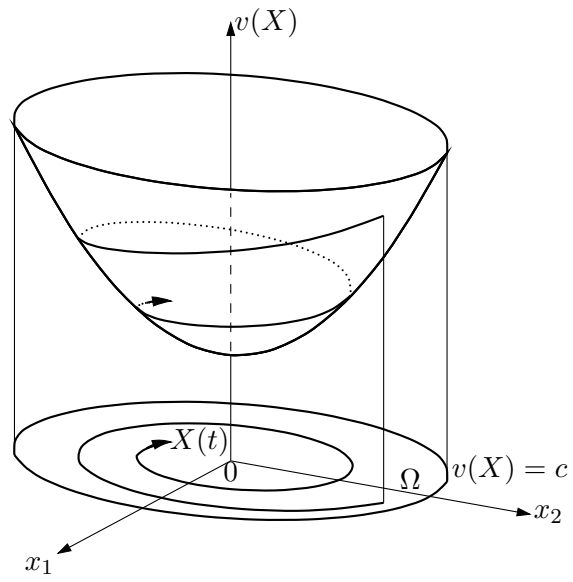

Figure 90: Illustrating a Lyapunov function [Lyap.m4].



Figure 91: Conestoga Sailing Club (illustrating the filling of arbitrary shapes) [csc.m4].

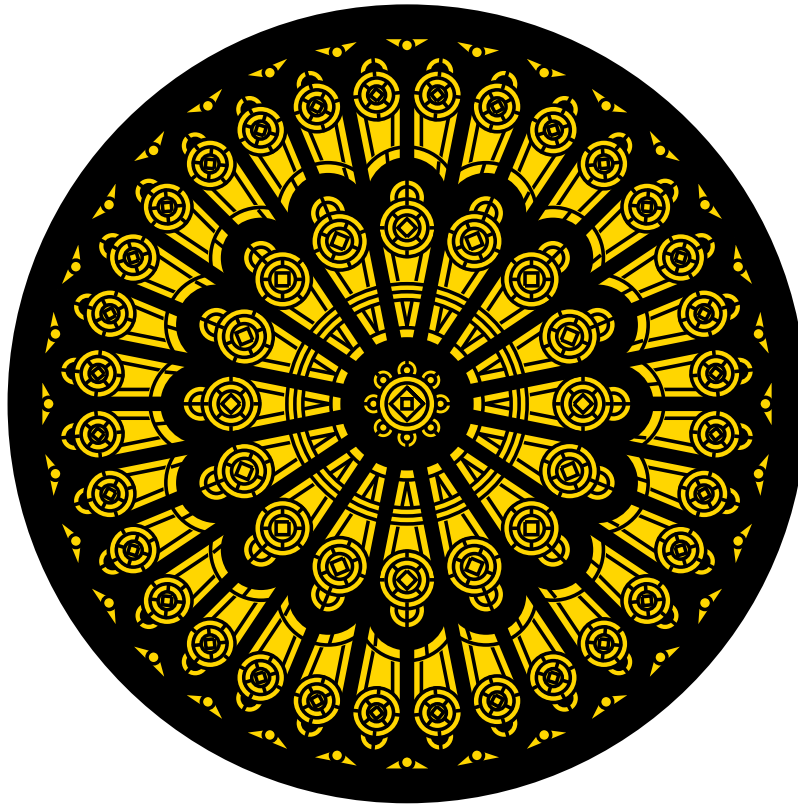

Figure 92: Redrawn from a detail of the set design for the musical *Dracula*, used for testing `dpic`. This diagram consumes much \LaTeX main memory but can be produced directly as pdf using `dpic -d`, as svg using `dpic -g`, or as postscript using `dpic -r` since no text formatting is required [rose.m4].

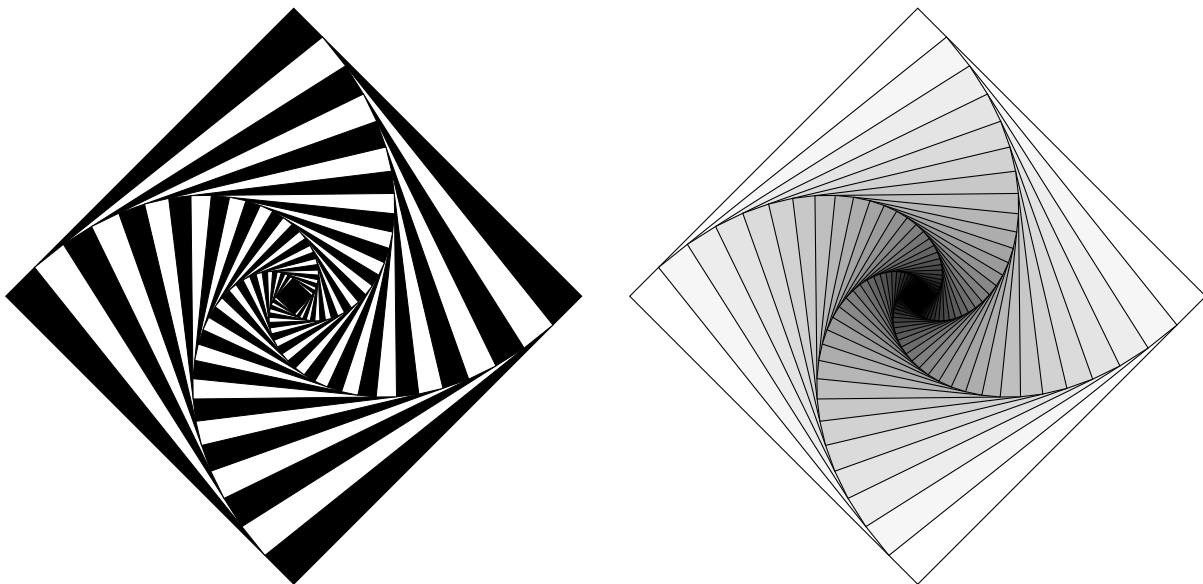

Figure 93: Variations on M. Goossens, S. Rahtz, and F. Mittelbach, *The \LaTeX Graphics Companion*, Addison-Wesley 1997, pp. 57-58 [diamond.m4].

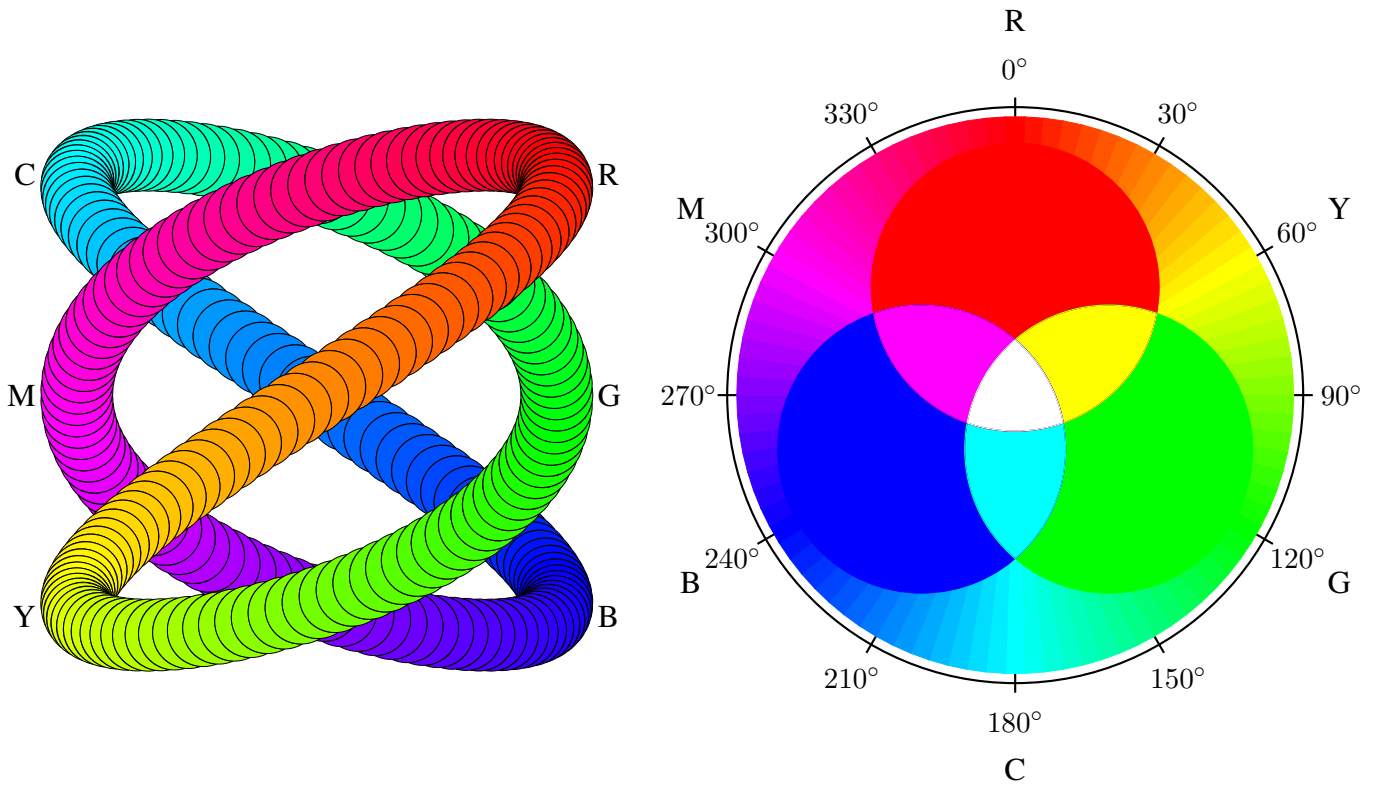

Figure 94: An exercise in calculating RGB colours [worm.m4].

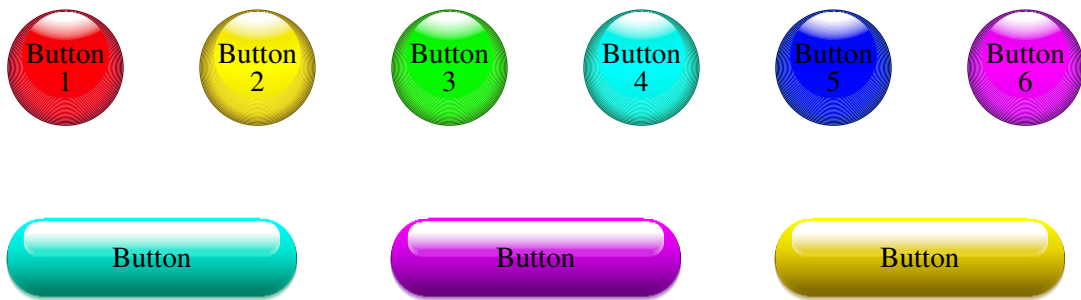

Figure 95: Shading in color [Buttons.m4].

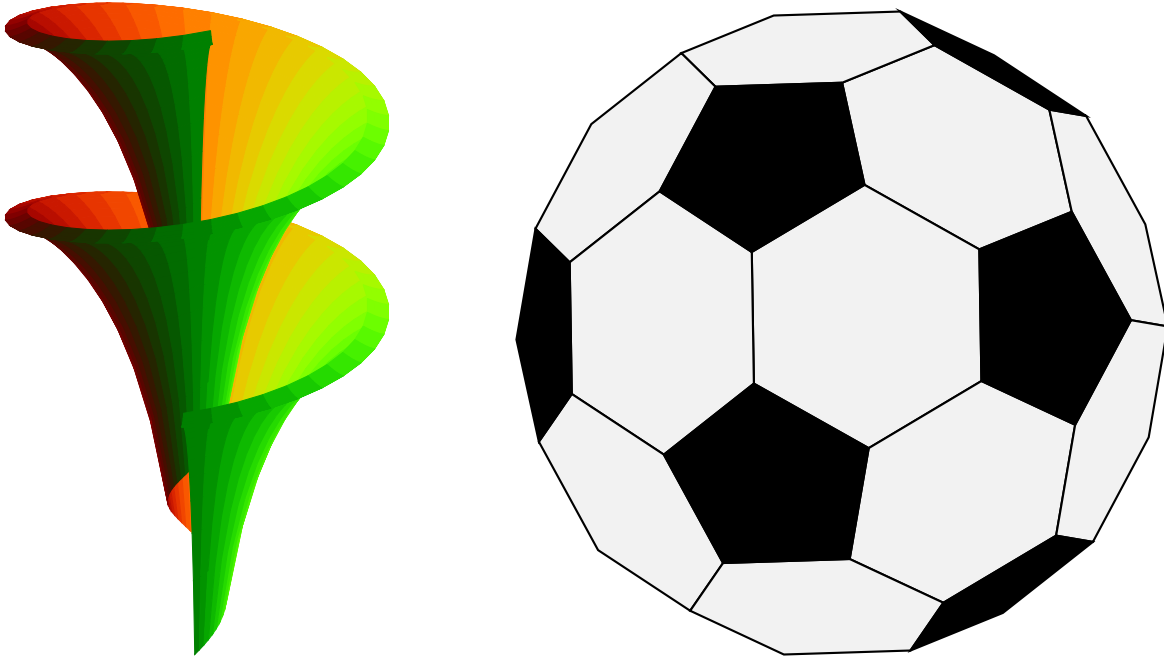

Figure 96: Dini surface and an icosahedron [Dini.m4].

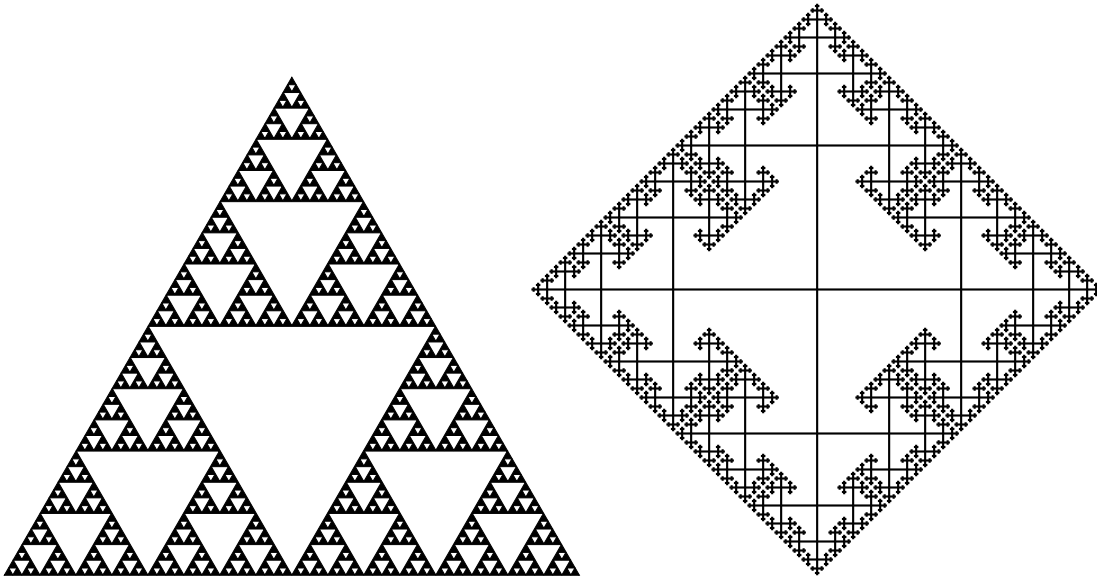

Figure 97: The Sierpinski triangle and a Cayley graph: tests of pic macro recursion [Sierpinski.m4].

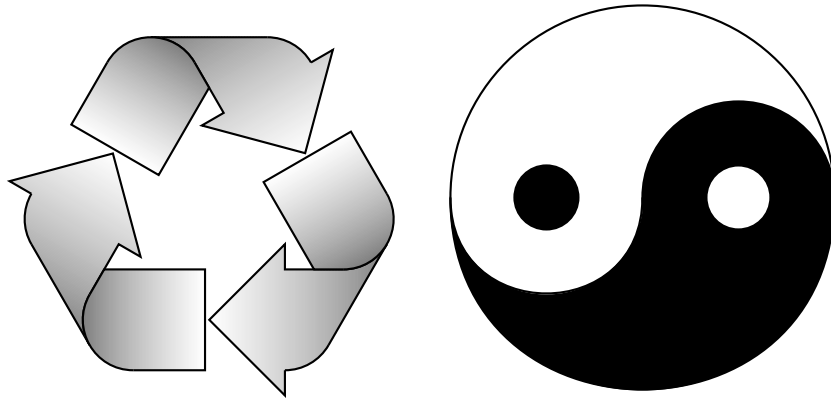

Figure 98: Modest repetition and partial fill [recycle.m4].

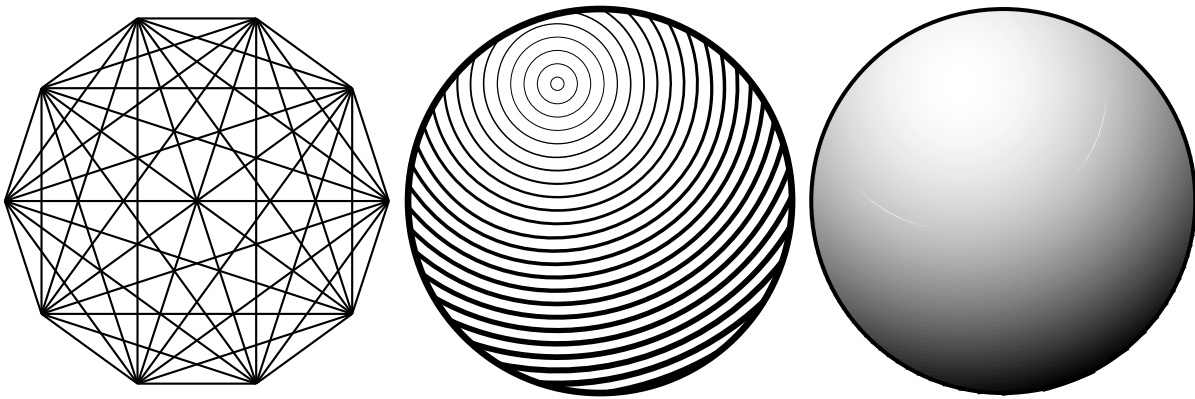

Figure 99: Simple diagrams that are easily drawn by looping [ex15.m4].

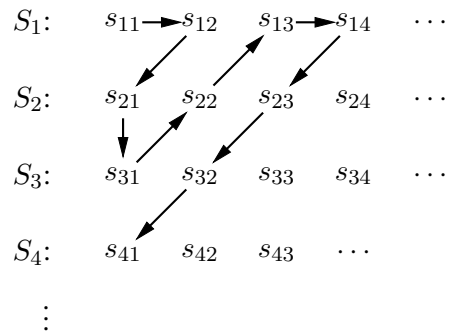

Figure 100: An example of enumeration [Counting.m4].

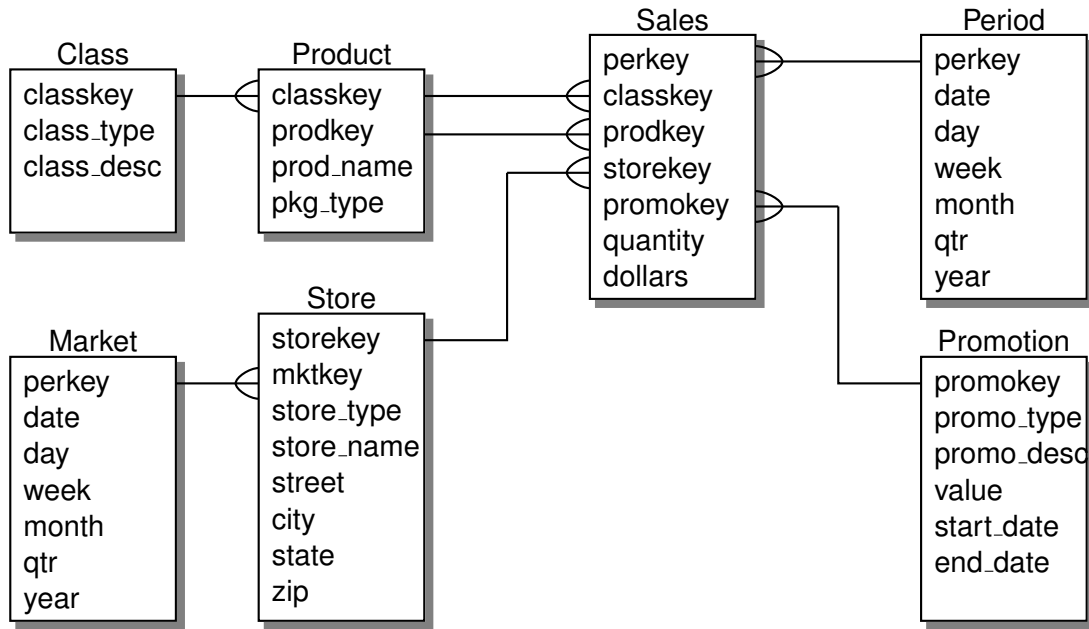

Figure 101: Illustrating shadebox and a custom crowfoot line termination [Crow.m4].

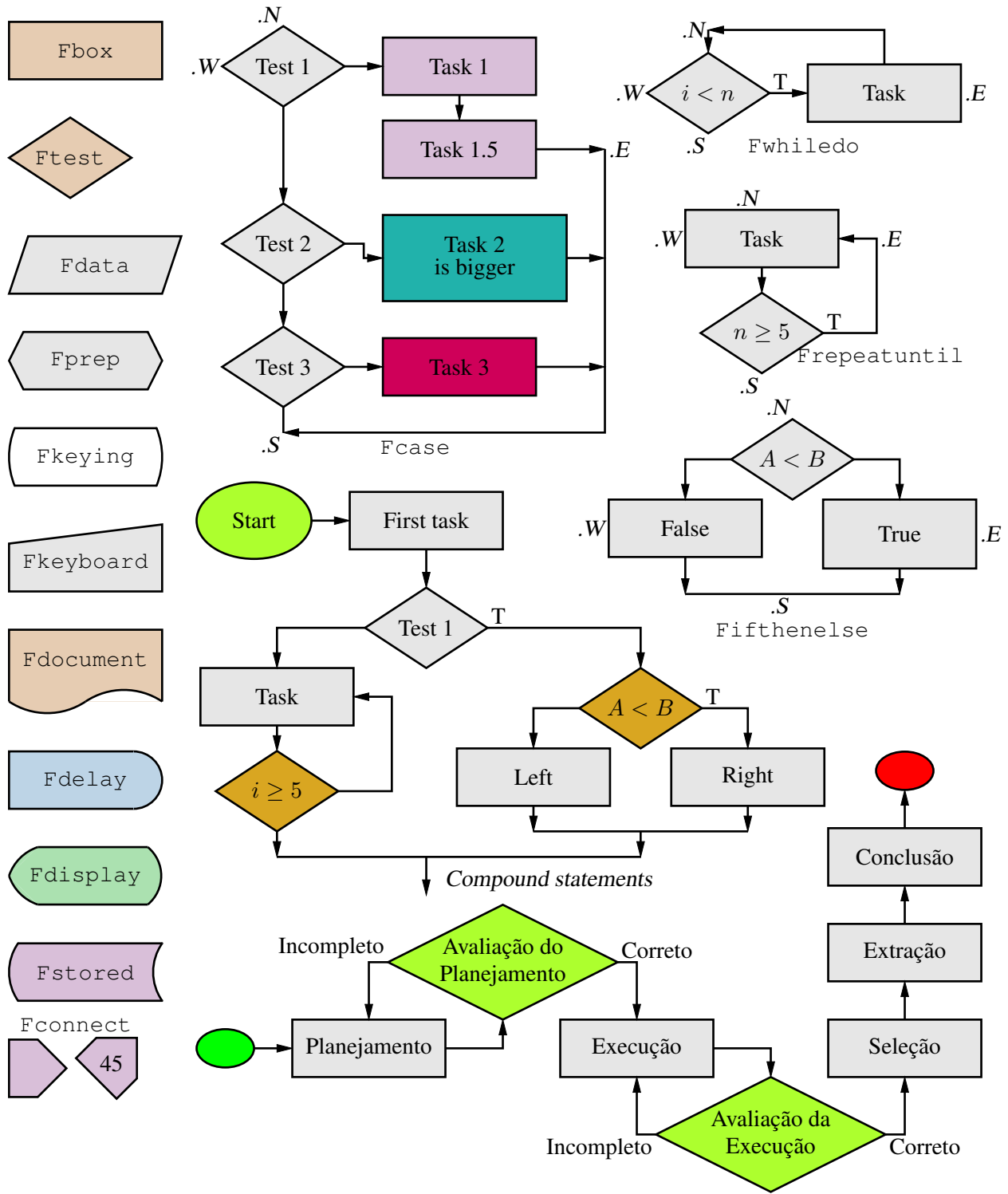

Figure 102: A flowchart sampler [Flow.m4].

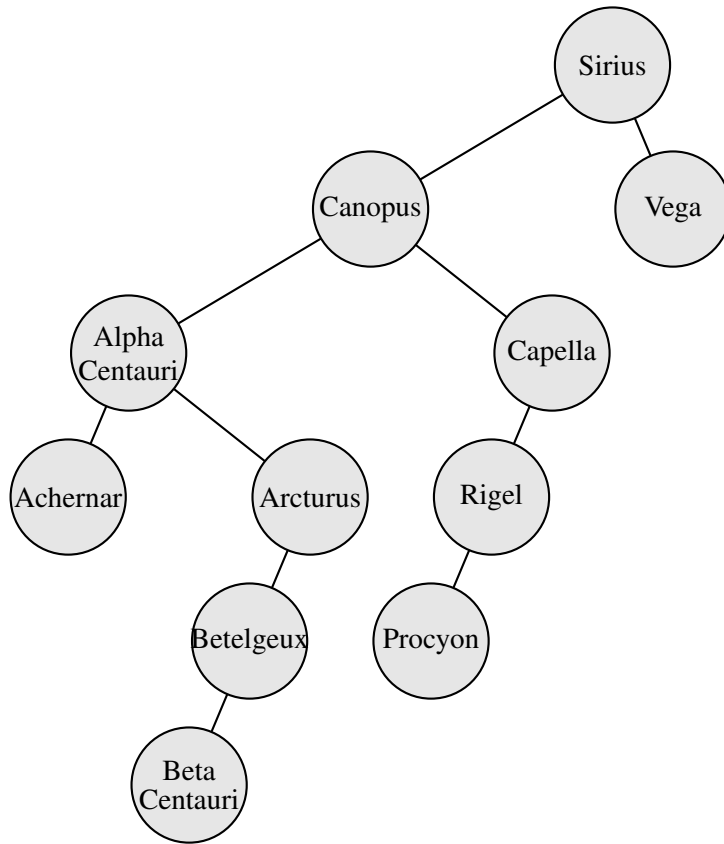

Figure 103: A binary tree [Btree.m4].

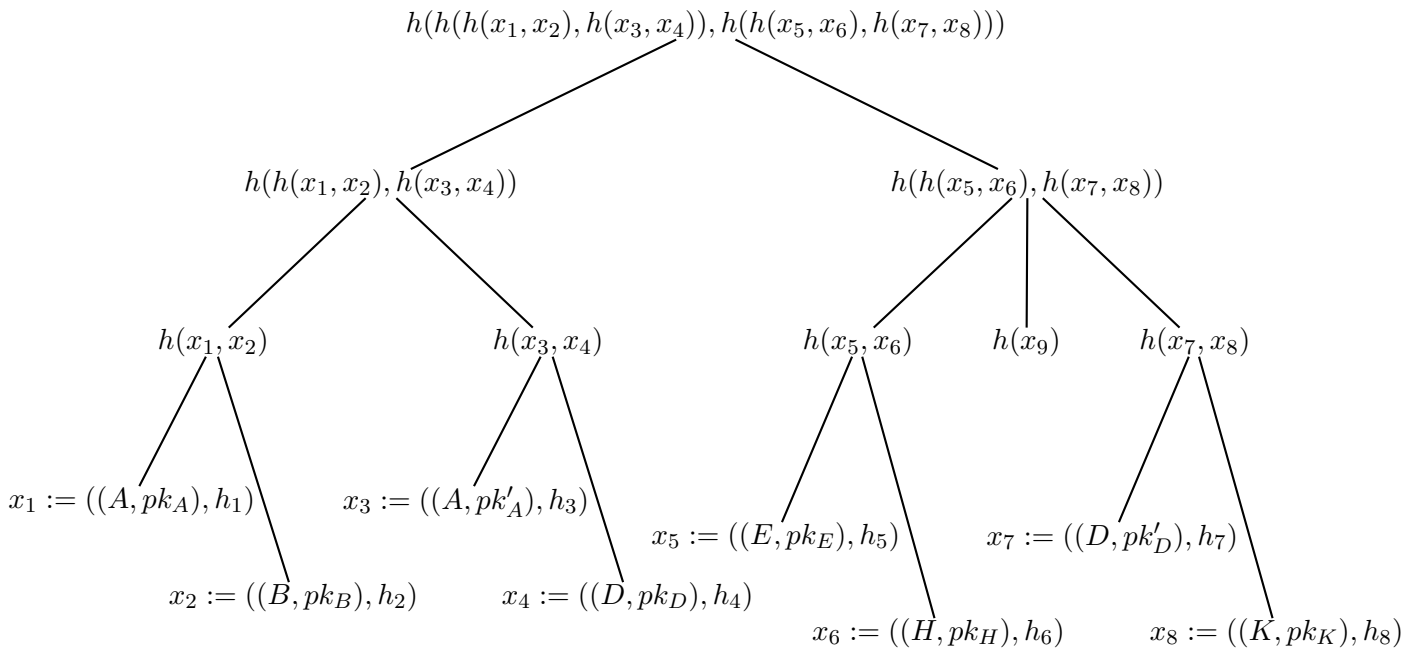

Figure 104: Another tree [Ttree.m4].



Figure 105: Overlaying a figure with line graphics [Incleps.m4].